

INW-AM100

Wall-Mounted Storage Box for the AM100 Swingout Mount Installation Guide

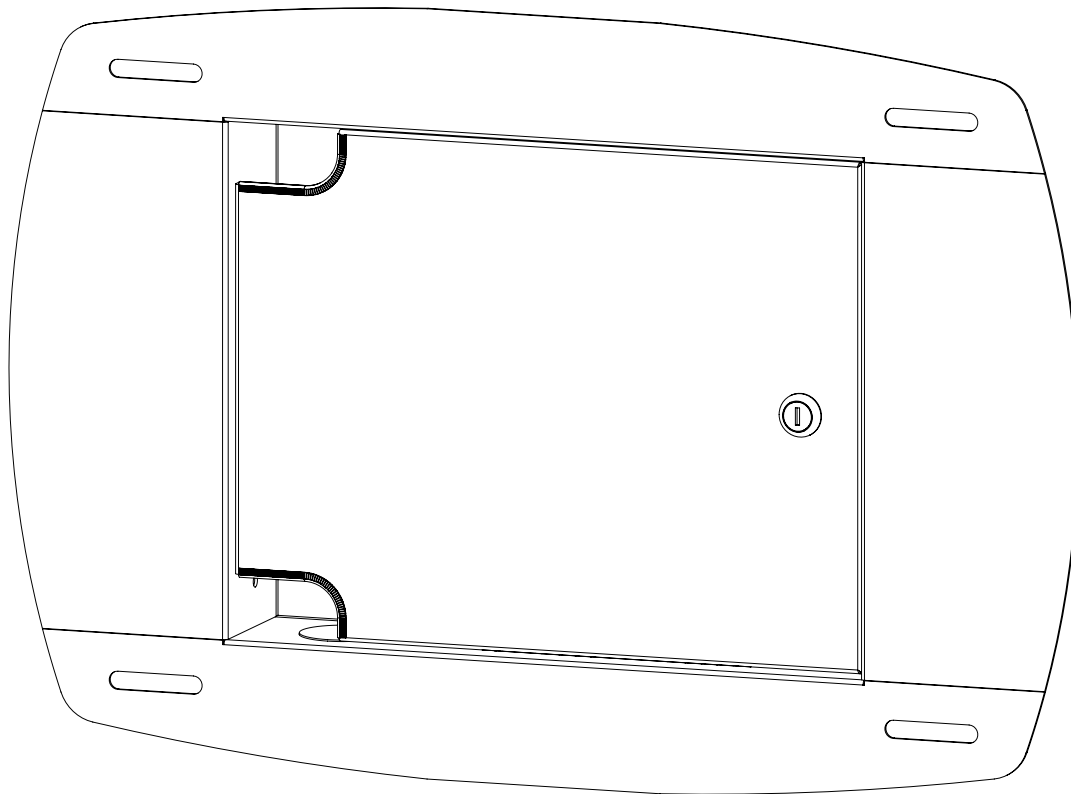

INW-AM100 Installation Guide

Included Components

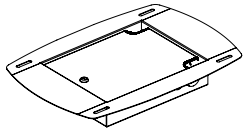

In Wall Box
(Qty. 1)



M4 x 5mm Screw
(Qty. 4)



#10 x 2" Wood Screw
(Qty. 4)

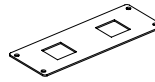

Snap In Plate
(Qty. 1)

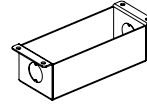

Snap In Bracket
(Qty. 1)



NEMA Plug
(Qty. 1)

Required for installation



Socket Wrench



1/2" / 14mm



Phillips Screw
Driver

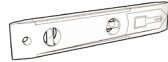

Leveler



Wood Stud
Finder



Pencil

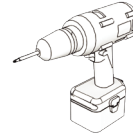

Drill Gun



1/4" / 6.5mm

1

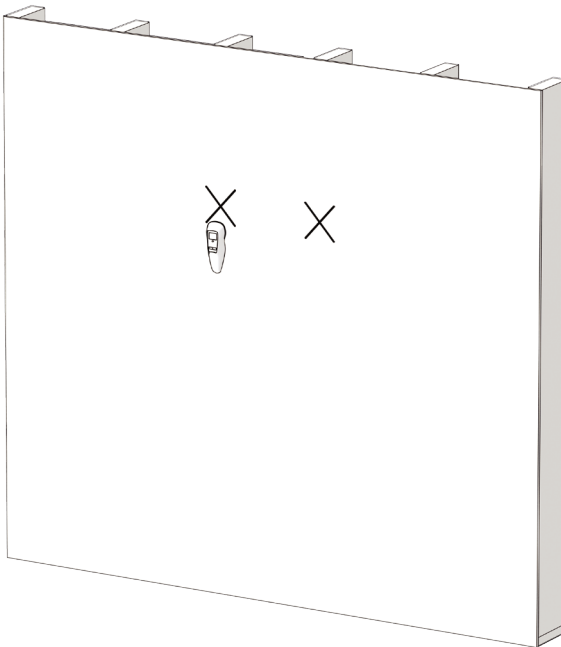

Before cutting out the in-wall box hole in the drywall confirm the tracing and stud hole marking are both level and safely between the two (2) 16" on-center studs.

Note: When using the INW-AM100 in-wall box as part of the installation with the AM100 swing out mount, we recommend using the mounting template supplied with the INW-AM100 to locate and mark the mounting holes.



INW-AM100 Installation Guide

2

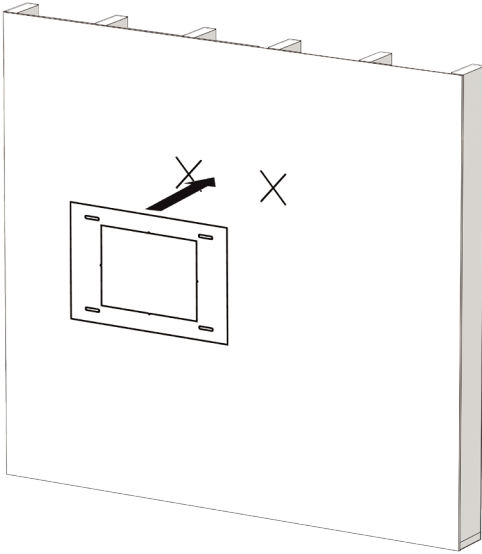

Use the 1/4" drill bit to create the initial hole along the trace line to insert the drywall saw.

3

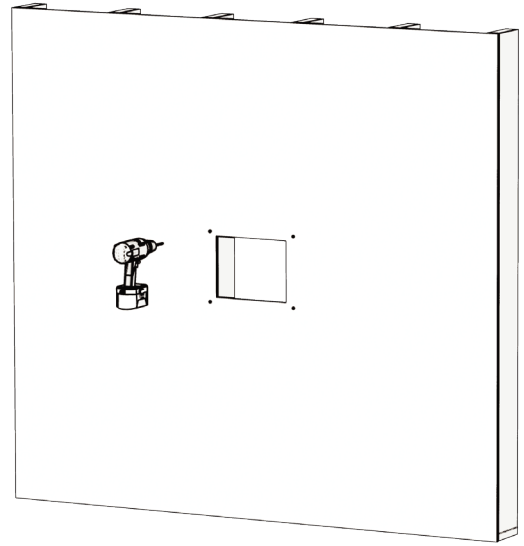

Caution: Make sure there are no exposed A/C wires or signal cables within the wall that might be cut while making the drywall cutout.

4

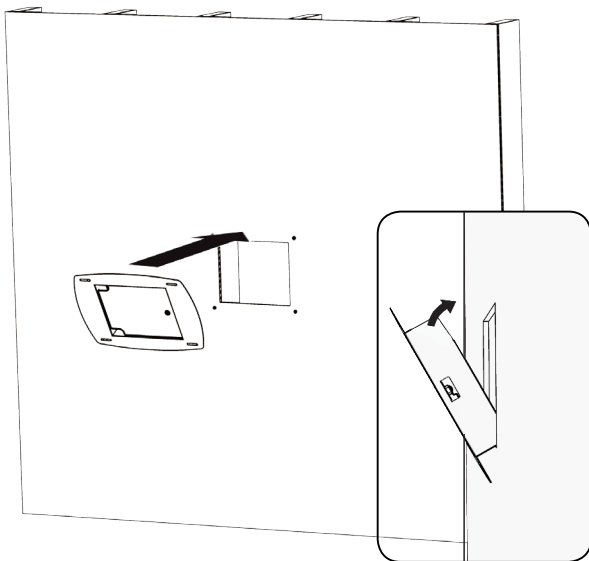

Once the four (4) mounting holes and square cutouts have been made in the drywall test, insert the in-wall box into the hole to confirm proper fit and level.

5

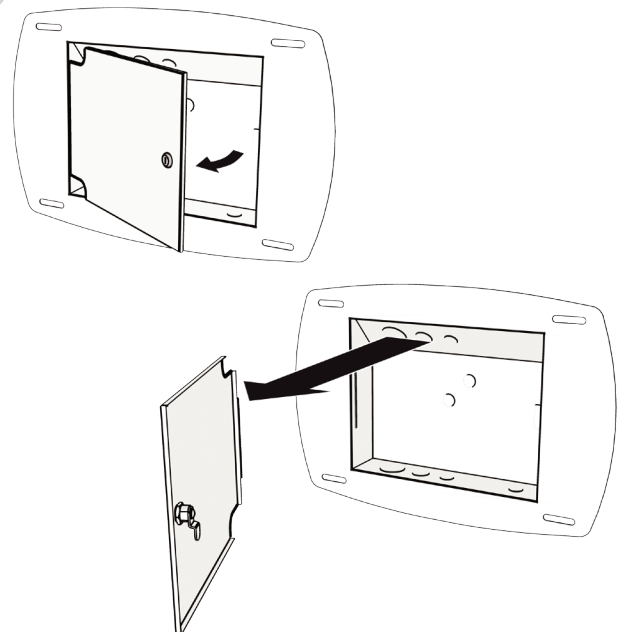

Remove the key lock front cover and set aside for later use.



INW-AM100

Installation Guide

6

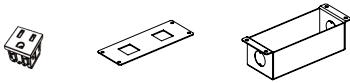
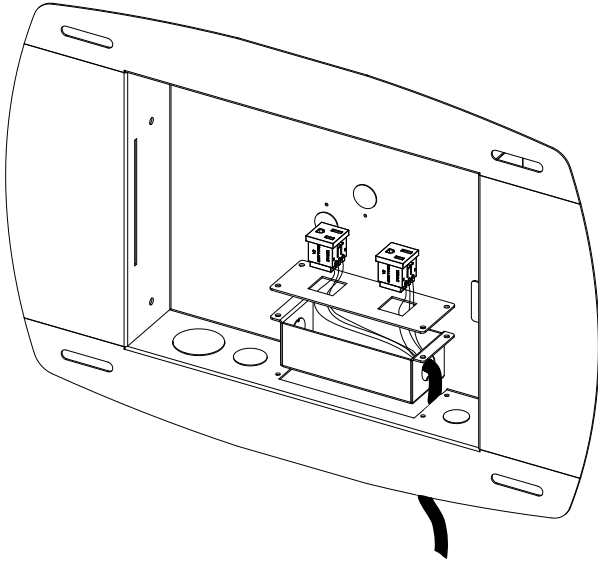

7

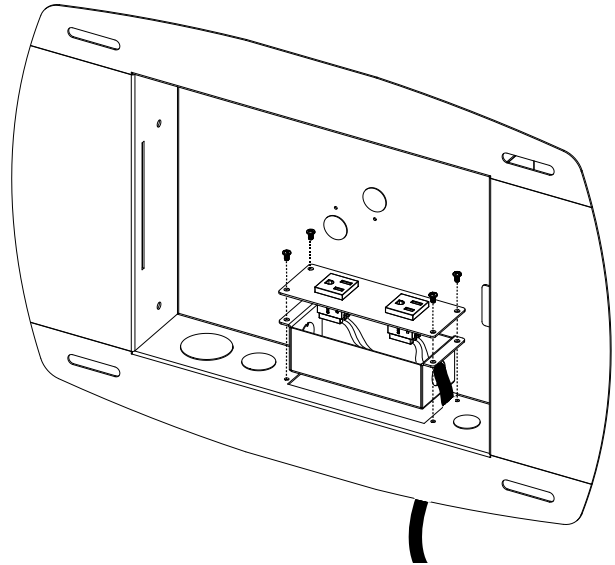

Attach the Snap in Plate and Snap in Bracket to the In-wall using four (4) M4 x5 mm screws.

8

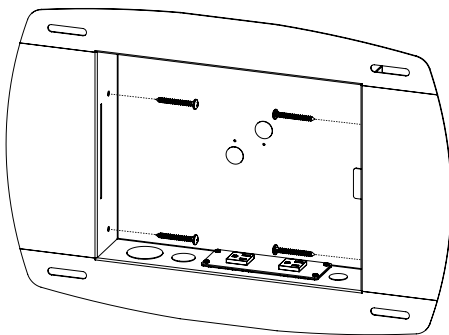
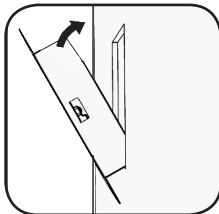

Fully insert the in-wall box assembly into the wall opening insuring the four (4) mounting hole slots are in line with the pre-drilled stud center pilot mounting holes.

9

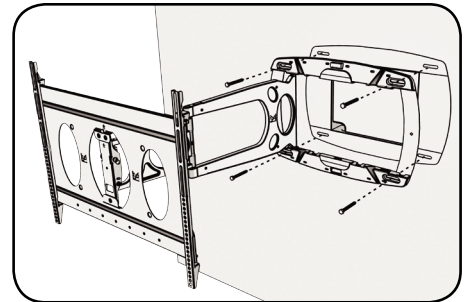
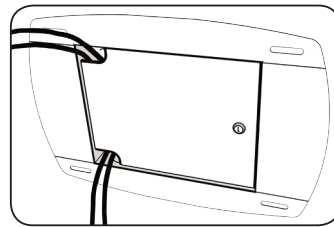

Refer to your installation instruction supplied with your AM100 articulating mount to complete the mounting process over the in place INW-AM100 in wall box.

Once the complete in-wall box and swing out mount are firmly installed together on the wall surface, power and signal cables can be separated and run along the upper and lower swing out arm cable paths.



PREMIER MOUNTS LIMITED LIFETIME WARRANTY

What and Who is Covered by this Limited Lifetime Warranty

Premier Mounts warrants all mounting products to be free from defects in material and workmanship for the lifetime of the original installation of the product.

What Premier Mounts Will Do

At the sole option of Premier Mounts, Premier Mounts will repair or replace any product or product part that is defective. If Premier Mounts chooses to replace a defective product or part, a replacement product or part will be shipped to you at no charge, but you must pay any related labor costs.

What is Not Covered: Limitations

Premier Mounts disclaims any liability for damage to mounts, adapters, displays, projectors, other property, or personal injury resulting, in whole or in part, from improper installation, modification, use or misuse of its products.

NOTWITHSTANDING ANYTHING TO THE CONTRARY IN THIS WARRANTY, THIS WARRANTY IS LIMITED TO FIVE YEARS FROM THE DATE OF PURCHASE IN THE EVENT THAT THE WARRANTED PRODUCT IS COMMERCIALY RENTED OUT.

Electrical products and components, such as amplifiers, speakers, motors, switches remote controls and related electrical items, are backed by a 3-year warranty.

Premier Mounts disclaims all other warranties, express or implied, including warranties of merchantability and fitness for a particular purpose. Premier Mounts is not responsible for incidental or consequential damages, including but not limited to, inability to use its products or labor costs for removing and replacing defective products or parts. Some states do not allow the exclusion or limitation of incidental or consequential damages, so the above limitation or exclusion may not apply to you.

What Customers Must Do for Warranty Service

If you discover a problem that you think may be covered by the warranty, you must report it in writing to the address below within thirty (30) days. Proof of purchase (an original sales receipt) from the original consumer purchaser must accompany all warranty claims. Warranty claims must also include a description of the problem, the purchaser's name, address, and telephone number. General inquiries can be addressed to Premier Mounts Customer Service at 1-800-368-9700. Warranty claims will not be accepted over the phone or by fax.

PREMIER MOUNTS

ATTN: Warranty Claims

500 W Central Ave, Suite A
Brea, CA 92821

How State Law Applies

This warranty gives you specific legal rights, and you may also have other rights which vary from state to state.

Premier Mounts intends to make this manual accurate and complete. However, Premier Mounts makes no claim that the information contained herein covers all details, conditions or variations, nor does it provide for every possible contingency in connection with the installation or use of this product. The information contained in this document is subject to change without notice or obligation of any kind. Premier Mounts makes no representation of warranty, expressed or implied, regarding the information contained herein. Premier Mounts assumes no responsibility for accuracy, completeness or sufficiency of the information contained in this document.

©PREMIER MOUNTS

500 W Central Ave, Suite A
Brea, CA 92821

USA & CANADA

Phone: 800-368-9700

Fax: 800-832-4888

e. orders@premiermounts.com

