

INSTRUCTION BOOK FOR
Ascender Electrol

DA-LITE[®]

Important Safety Instructions

When using your video equipment, basic safety precautions should always be followed, including the following:

1. Read and understand all instructions before using.
2. Position the cord so that it will not be tripped over, pulled, or contact hot surfaces.
3. If an extension cord is necessary, a cord with a current rating at least equal to that of the appliance should be used. Cords rated for less amperage than the appliance may overheat.
4. To reduce the risk of electric shock, do not disassemble this appliance. Contact an authorized service dealer when repair work is required. Incorrect reassembly can cause electric shock when the appliance is used subsequently.
5. The use of an accessory attachment not recommended by the manufacturer may cause a risk of fire, electric shock, or injury to persons.

Save These Instructions

Pre-Installation

1. The Ascender screen must be installed on a flat, level surface.
2. Remove the white shipping braces (mounted at the end of the arms to the back of the case).
3. Refer to the chart below for minimum overhead clearance required to raise the screen.

4:3 Video Format

Diagonal	Extended Height
100"	94"
120"	104"
150"	121"
180"	139"
200"	149"

16:9 HDTVFormat

Diagonal	Extended Height
106"	86"
119"	92"
133"	99"
159"	112"

4. Allow 12" clearance from back of screen housing to allow arms to extend properly.
5. Remove packing paper from fabric roller. DO NOT use a knife or sharp object to remove the paper.

Screen Operation

⚠ CAUTION!

The arms of the screen are under high spring tension.

Do not stand over the screen while it is operating.

Do not sit, stand, or put anything on the screen case door.

Do not apply anything (wood finish, carpet, additional laminate, etc.) to the screen case door. Any weight added to the screen case door may cause the screen to malfunction over time.

The case door activates a safety switch inside the screen case. If you attempt to raise the screen while something is holding the door shut, the motor will reverse and retract the screen. The door must be fully closed to activate this switch. Be sure there is nothing holding the door ajar.

⚠ ATTENTION! Les ressorts des bras de l'écran sont fortement tendus.

Ne vous placez pas devant l'écran pendant son fonctionnement.

Ne vous asseyez pas, ne vous tenez pas debout, ou ne placez aucun objet sur la trappe du caisson de l'écran.

Ne couvrez pas la trappe du caisson de l'écran avec un revêtement en bois, de la moquette, des stratifiés supplémentaires, etc. Tout poids ajouté à la trappe du caisson de l'écran pourrait entraîner, avec le temps, le dysfonctionnement de l'écran.

La trappe du caisson active un interrupteur de sécurité situé à l'intérieur du caisson de l'écran. Si vous essayez d'élever l'écran alors que quelque chose tient la trappe fermée, le moteur rétractera l'écran. La trappe doit être complètement fermée pour activer cet interrupteur. Vérifiez que la trappe n'est pas entrouverte.

Screen Operation (continued)

1. The Ascender screen can be operated by the included wall switch or by optional remote controls (IR or RF).
2. To raise the screen, simply push and release the wall switch. The screen will stop at its preset position. If you push the switch a second time while it is rising, the screen will stop. By pushing the switch a third time the screen will retract and close.
3. To lower the screen from the fully up position, press and release the wall switch and the screen will retract and close.
4. Test the screen by running it up and down a few times. Be prepared to stop the screen if needed.

⚠ CAUTION! Excessive continuous operation may cause overheating. If this happens, the motor will shut off until it cools to normal operating temperature. Standard duty cycle is 1 min. on / 15 min. off.

⚠ ATTENTION! Le fonctionnement continu et excessif peut provoquer une surchauffe et l'arrêt du moteur. Si cela se produit, les moteurs s'arrêteront jusqu'à qu'ils se soient refroidis à la température normale de fonctionnement. Le cycle de fonctionnement normal est de 1 min. en marche / 15 min. à l'arrêt.

Ascender Electrol® Installation

1. For installations where the Ascender will be set on the floor, the box must be secured to floor in at least six places (recommended hardware is #12 x 2" L wood screws)(Figure 1).
2. For installations where the Ascender will be recessed into the floor, the box must be secured in at least six places (recommended hardware is #12 x 2" L wood screws)(Figure2).

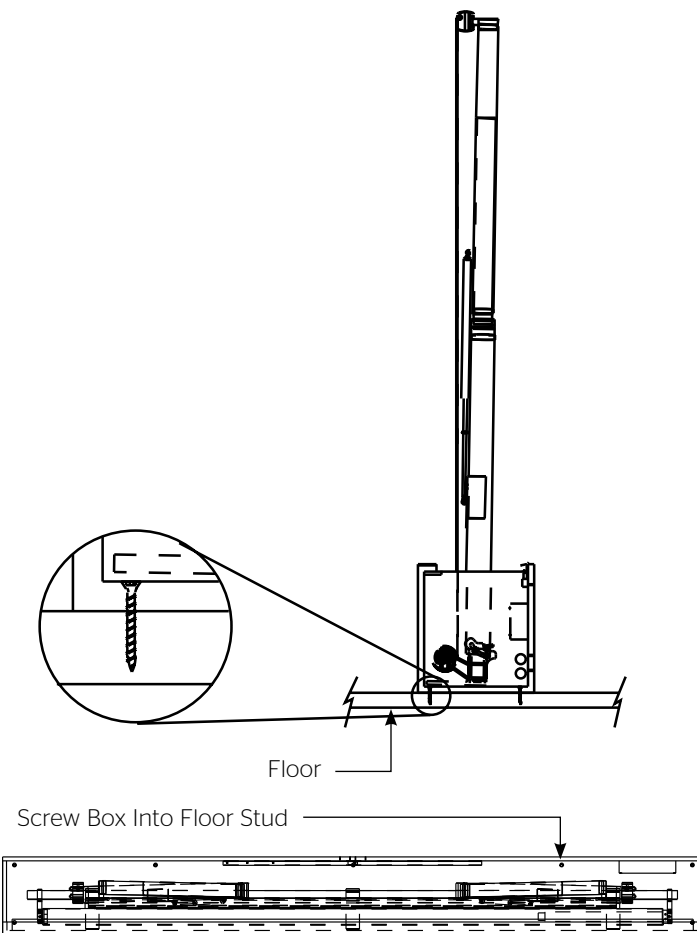

Figure 1

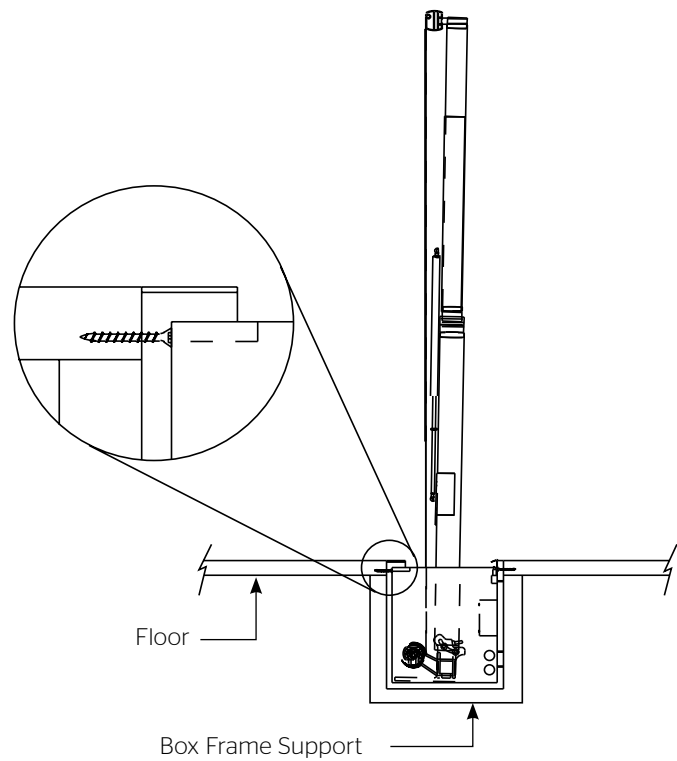

Figure 2

Ascender Electrol® Installation

⚠ WARNING: To prevent electrical shock or damage to the low voltage control (LVC), do not apply power to the LVC until all connections are complete. Make sure power is turned off on all wires before making connections.

⚠ AVERTISSEMENT: pour éviter tout choc électrique ou d'endommager le tableau de contrôle basse tension, n'alimentez ce dernier qu'une fois tous les branchements effectués. Vérifiez qu'aucun câble n'est alimenté avant d'effectuer les branchements.

LOW VOLTAGE CONNECTIONS:

Wall Switch

1. Install wall switch where desired.
2. Use 2-conductor 20-24 gauge wire to extend the switch wire to the required length.
3. Connect the wire from the switch to the wire labeled "wall switch". Refer to Figure 3.

⚠ CAUTION: Never apply voltage to the wall switch lead or the LVC will be damaged.

⚠ ATTENTION: N'appliquez jamais une tension aux fils du commutateur mural sinon le tableau de contrôle basse tension sera endommagé.

Control Panel

A control panel may be connected to the LVC by using the wall switch wire lead. The control panel must provide a momentary, dry contact closure of at least 1/2 second.

1. Use 2-conductor 20-24 gauge wire to connect the control panel to the wall switch lead.
2. A momentary closure when the screen is down will be an "up" command.
3. A momentary closure when the screen is fully extended will be a "down" command.
4. A momentary closure while the screen is in motion will be a "stop" command.

⚠ CAUTION: Never apply voltage to the wall switch lead or the LVC will be damaged.

⚠ ATTENTION: N'appliquez jamais une tension aux fils du commutateur mural sinon le tableau de contrôle basse tension sera endommagé.

120V/240V Connections:

AC Power Source

1. Refer to Figure 3 for electrical connections. Wiring designated as external is to be completed by installer conforming to local and national codes.

NOTE: Must be installed in accordance with the requirements of the Local Building Codes, the Canadian Electrical Code (CEC), CAN/CSA C22.1 and the National Electric Code (NEC), NFPA 70. An appropriate disconnect device shall be provided as part of the building installation.

2. Use 14-18 gauge wire to connect power to the LVC wires labeled "AC power input". Refer to Figure 3.
3. Connect the building ground wire to the ground lug on the metal housing.

Optional Wireless Remote Connections:

Radio Frequency Remote

1. Remove the center cover plate of the LVC box.
2. Route the receiver wire through the round plastic bushing and plug it into the onboard socket marked "EYE". Refer to Figure 3.

Infrared Remote

1. Remove the center cover plate of the LVC box.
2. Route the receiver wire through the round plastic bushing and plug it into the onboard socket marked "EYE". Refer to Figure 3.

120V Wiring Diagram

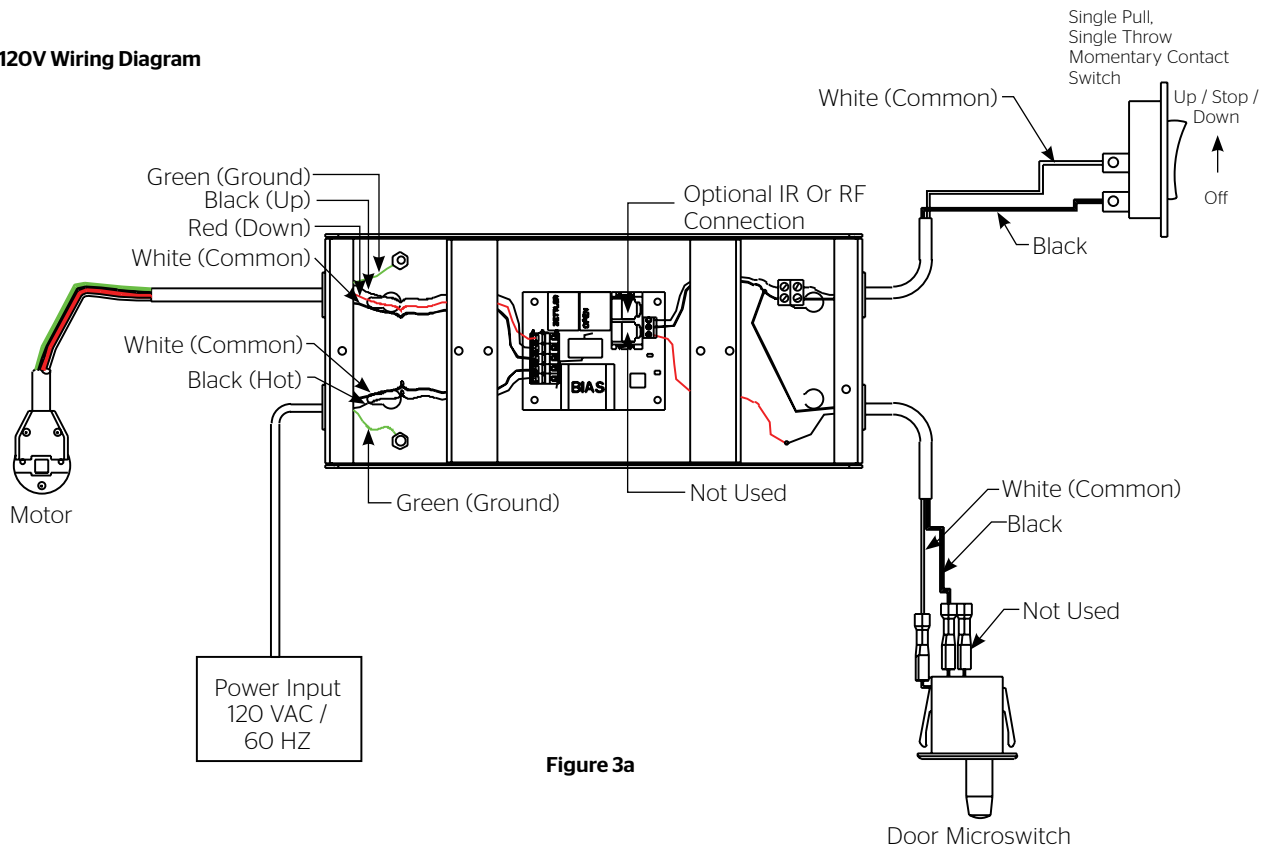

Figure 3a

240V Wiring Diagram

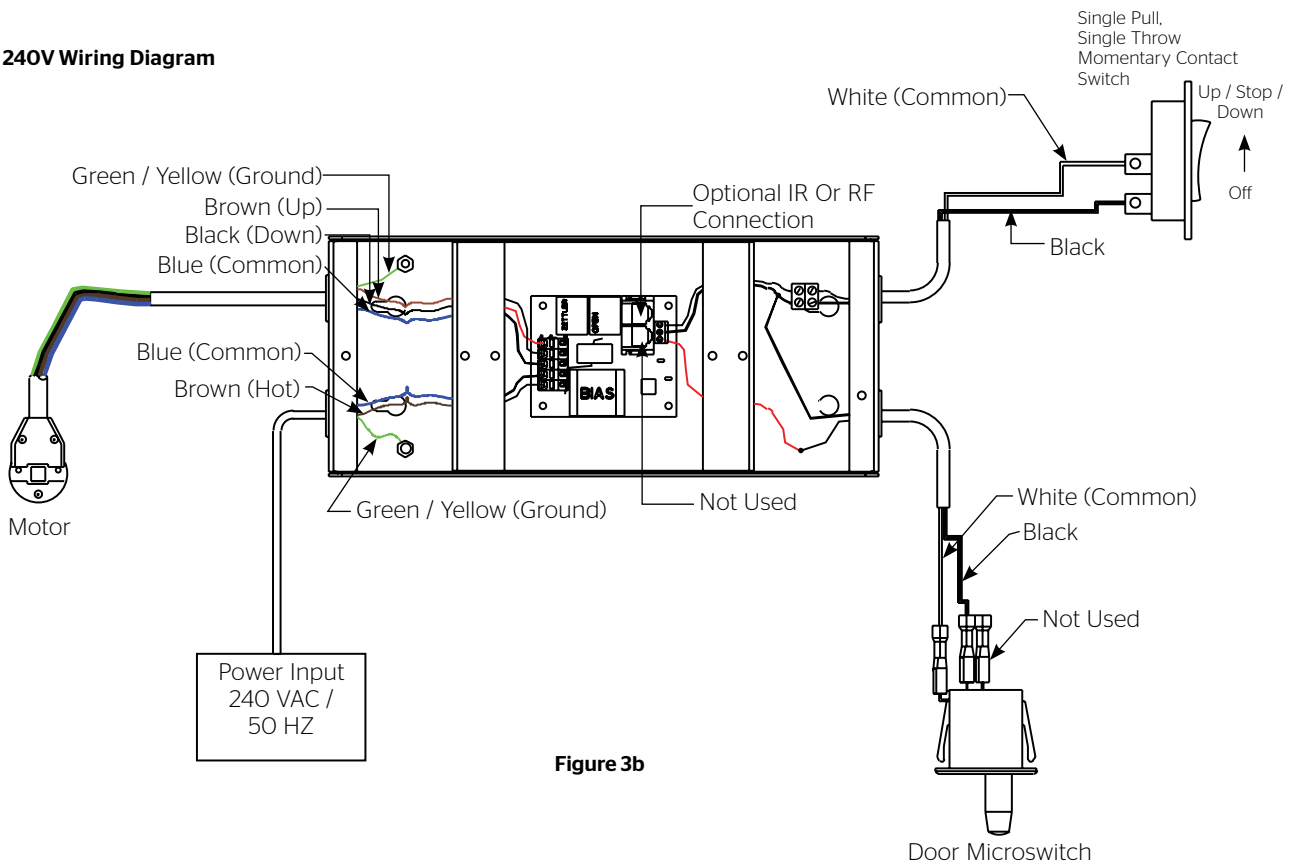

Figure 3b

Screen Adjustment

The screen stop positions are preset at the factory. Should it be necessary to adjust for more or less travel proceed as follows (Figure 4).

To Increase Screen Height

1. Turn the white limit adjuster counterclockwise one-quarter turn at a time. Run the screen down about one foot and then back up to test the stop position. Repeat until the desired position is set.

⚠ CAUTION! Do not adjust for more height than what was ordered. Adjusting too high may cause the arms to lock and not retract properly. There must be at least 1-1/2 wraps of fabric on the roller at all times.

⚠ ATTENTION: N'effectuez pas de réglage pour obtenir un déroulement supérieur à celui commandé. Un ajustement trop élevé peut entraîner le verrouillage des bras et un enroulement incorrect. 1 à 1/2 tour de toile doit être toujours maintenu dans le cylindre.

To Decrease Screen Height

1. Turn white limit adjuster clockwise one-quarter turn at a time. Run the screen up to test the stop position. Lower the screen about one foot and turn limit adjuster again. Repeat until the desired position is set.

To Adjust The Down Position

1. Raise the screen about one foot and stop. Turn the red limit adjuster counterclockwise one-quarter turn to increase the down travel.

⚠ CAUTION! Do not adjust the screen down too far. This will strain the motor and screen. The lid of the box should just close when the motor stops.

⚠ ATTENTION: Ne déroulez pas trop l'écran. Cela forcera le moteur et l'écran. Le couvercle du caisson devrait se fermer lorsque le moteur s'arrête.

2. Turn the red limit adjuster clockwise one-quarter turn at a time to decrease the amount of down travel. Run the screen down to test the stop position. Repeat until the desired position is set.

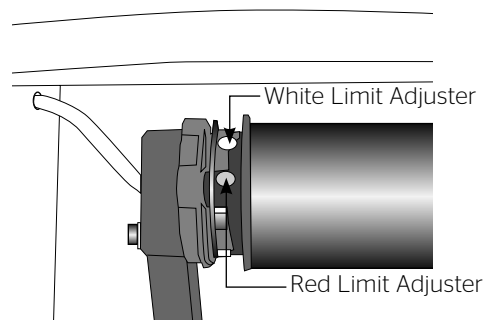

Figure 4

Keystone Adjustment

The Ascender screen can be adjusted to reduce keystoneing of the video image.

This procedure requires two people. One to hold the arms and another to make the adjustments.

1. Raise the screen to the fully extended position.
2. Loosen the two lock nuts on the end of one arm (Figure 5).
3. Turn the adjusting nut and carefully push the arm in the required direction.
4. Tighten the lock nuts.
5. Repeat steps 2 to 4 for the other arm.

NOTE: Make sure that the screen surface does not rub against the edge of the case.

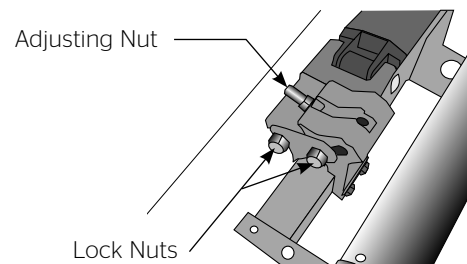

Figure 5

Troubleshooting

Symptom	Cause	Solution
Screen will not operate or will not go "down". Motor does not hum.	Tripped circuit breaker.	Reset circuit breaker.
	No power to operating switch or junction.	Check above. Tighten all loose wire connections. Correct any improper connections. "Down" Position. Check for power across black and white leads.
	Power at junction box Thermal overload tripped.	Let motor cool down for 15 minutes. Try again.
	Broken wire in the "down" position.	Check for continuity. Cut off old splice and reconnect.
Motor hums.	Defective motor, limit switch or capacitor.	Replace motor assembly. NOTE: Motor is a sealed assembly.
	Capacitor burned out.	Replace motor assembly.
Screen will not move "up" Motor does not hum	Tripped circuit breaker.	Reset circuit breaker.
	No power to operating switch or junction.	Check above. Tighten all loose wire connections. Correct any improper connections. "Up" Position. Check for power across black and white leads.
	Power at junction box Thermal overload tripped.	Let motor cool down for 15 minutes. Try again.
	Broken wire in the "up" position.	Check for continuity. Cut off old splice and reconnect.
	Defective motor, limit switch or capacitor.	Replace motor assembly. NOTE: Motor is a sealed assembly.
	Capacitor burned out.	Replace motor assembly.
Motor hums.		
Incorrect stopping position in downward direction.	"Down" limit switch out of adjustment.	See installation instructions.
Incorrect stopping position in upward direction.	"Up" limit switch out of adjustment.	Adjust "up" limit switch. See installation instructions
Noise. NOTE: Screen will operate with a low pitched hum.	Grinding due to foreign object in screen rubbing on roller or fabric.	Remove foreign object.
	Gear noise.	Replace motor assembly.
Coasting.	Defective brake.	Replace motor assembly.

Conditions for Transportation and Storage

- Temperature: Between 40 - 100°F (5 - 40°C)
- Relative Humidity: 30% to 70%, non-condensing
- Always keep the projection screen horizontal during transport and storage
- Make sure the entire package is supported when stored
- Do not stack more than six projection screens on top of each other
- Make sure the heaviest package is placed at the bottom of the stack

Screen surface should be allowed to air out once every two months, or otherwise used on a regular basis, if the temperature is above 72°F (22°C) and at least once every month if the temperature goes above 85°F (30°C).

LIMITED FIVE YEAR WARRANTY ON DA-LITE PRESENTATION PRODUCTS

Milestone AV Technologies LLC warrants certain Da-Lite branded products to the original purchaser only, to be free from defects in materials and workmanship for a period of five (5) years from the date of purchase by the original purchaser; provided they are properly operated according to Da-Lite's instructions and are not damaged due to improper handling or treatment after shipment from the factory.

This warranty does not apply to equipment showing evidence of misuse, abuse or accidental damage, or which has been tampered with or repaired by a person other than authorized Da-Lite personnel.

Da-Lite's sole obligation under this warranty shall be to repair or to replace (at Da-Lite's option) the defective part of the merchandise. Returns for service should be made to your Da-Lite dealer. If it is necessary for the dealer to return the screen or part to Da-Lite, transportation expenses to and from Da-Lite are payable by the purchaser and Da-Lite is not responsible for damage in shipment. To protect yourself against damage or loss in transit, insure the product and prepay all transportation expenses.

TO THE MAXIMUM EXTENT PERMITTED BY APPLICABLE LAW, THIS WARRANTY IS IN LIEU OF ALL OTHER WARRANTIES, EXPRESS OR IMPLIED, INCLUDING WARRANTIES AS TO FITNESS FOR USE AND MERCHANTABILITY. Any implied warranties of fitness for use, or merchantability, that may be mandated by statute or rule of law are limited to the five (5) year warranty period. This warranty gives you specific legal rights, and you may also have other rights, which vary from state-to-state. **TO THE MAXIMUM EXTENT PERMITTED BY APPLICABLE LAW, NO LIABILITY IS ASSUMED FOR EXPENSES OR DAMAGES RESULTING FROM INTERRUPTION IN OPERATION OF EQUIPMENT, OR FOR INCIDENTAL, DIRECT, OR CONSEQUENTIAL DAMAGES OF ANY NATURE.**

In the event that there is a defect in materials or workmanship of a Da-Lite product, you may contact our Customer Care Specialists at 3100 North Detroit Street, Warsaw, IN 46582, (574) 267-8101, (800) 622-3737.

IMPORTANT: THIS WARRANTY SHALL NOT BE VALID AND DA-LITE BRANDED PRODUCTS SHALL NOT BE BOUND BY THIS WARRANTY IF THE PRODUCT IS NOT OPERATED IN ACCORDANCE WITH THE DA-LITE WRITTEN INSTRUCTIONS.

Keep your sales receipt to prove the date of purchase and your original ownership.



FOR YOUR IMAGE | legrandav.com

USA P 866.977.3901 E info@da-lite.com
CANADA P 877.345.4329 E canadainfo@milestone.com
EMEA P +31 495 580 840 E emea.sales@milestone.com
APAC P +852 2145 4099 E asia.da-lite@milestone.com

In British Columbia, Milestone AV Technologies ULC carries on business as MAVT Milestone AV Technologies ULC.
©2018 Milestone AV Technologies. DL-0279 (Rev. 4) 7/18 Da-Lite is a registered trademark of Milestone AV Technologies. All other brand names or marks are used for identification purposes and are trademarks of their respective owners. All patents are protected under existing designations. Other patents pending.