

INSTALLATION INSTRUCTIONS

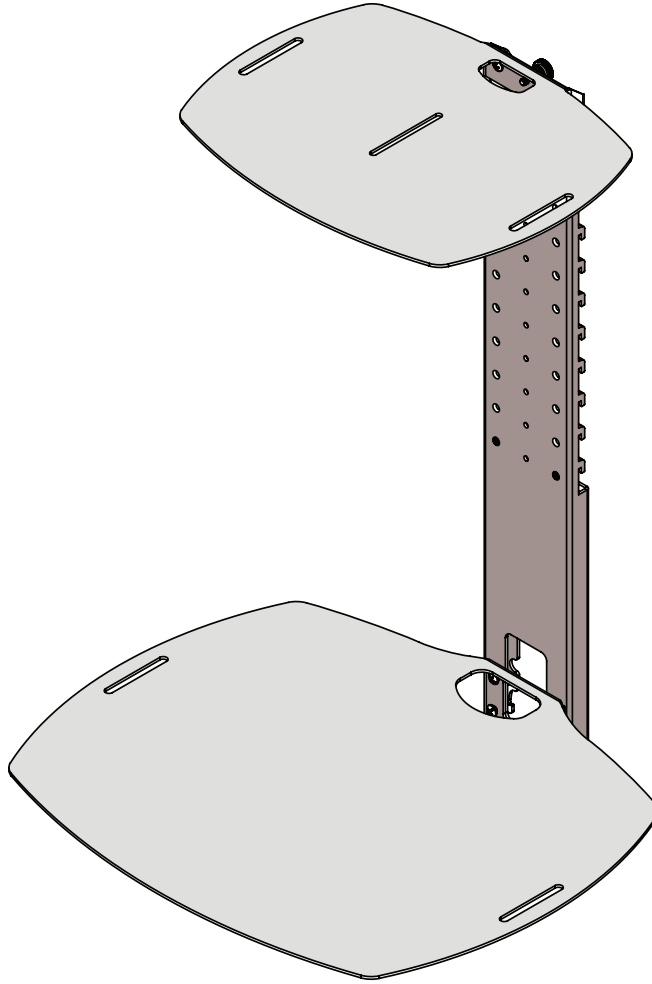

SHLF-VE

AV Shelving System for Low Profile Flat-Panel Mounts

NORTH AMERICA

3130 East Miraloma Avenue
Anaheim, CA 92806 USA

USA and Canada

Phone: 1.800.368.9700
Fax: 1.800.832.4888

Other Locations

Phone: (001).714.632.7100
Fax: (001).714.632.1044

EUROPE

Swallow House,
Shilton Industrial Estate,
Shilton, Coventry, England CV79JY

Phone: +44 (0) 2476 614700
Fax: +44 (0) 2476 614710



Contents

Contents 2

Warning Statements 2

Installation Tools 3

Parts List 3

Features 4

Installing the SHLF-VE 5

 Introduction 5

 Assembling the Video Conference Shelf Assembly 5

 Attaching the Video Conference Shelf Assembly to a P-Series Mount 6

 Attaching the Video Conferencing Camera 7

 Large Shelf Assembly 8

 Attaching the Large Shelf Assembly to a P-Series Mount 8

 Using the Equipment Strap 9

 Attaching Additional Shelves (Optional) 10

 Using Different Combos 12

Technical Specifications 12

Warranty 13

Disclaimer 13

Warning Statements



Prior to the installation of this product, these installation instructions must be read and completely understood. Keep these installation instructions in an easily accessible location for future reference.



Proper installation procedure by a qualified service technician must be followed, as outlined in these installation instructions. Failure to do so could result in property damage, serious personal injury, or even death.



Safety measures must be practiced at all times during the assembly of this product. Use proper safety equipment and tools for the assembly procedure to prevent personal injury.



Premier Mounts does not warrant against damage caused by the use of any Premier Mounts product for purposes other than those for which it was designed or damage caused by unauthorized attachments or modifications, and is not responsible for any damages, claims, demands, suits, actions or causes of action of whatever kind resulting from, arising out of or in any manner relating to any such use, attachments or modifications.



At least two qualified people should perform the assembly procedure. Personal injury and/or property damage can result from dropping or mishandling your electronic equipment.



Be aware of the mounting environment. If drilling and/or cutting into the mounting surface, always make sure that there are no electrical wires on the floor. Cutting or drilling into an electrical line may cause serious personal injury.



Do not install on a structure that is prone to vibration, movement or chance of impact. Failure to do so could result in damage to the flat-panel and/or damage to the mounting surface.



This product is intended for indoor use only. Use of this product outdoors could lead to product failure and/or serious personal injury.



Do not install near sources of high heat. Do not install on a structure that is prone to vibration, movement or chance of impact.





Contact Premier Mounts with any questions:
(800) 368-9700
techsupport@mounts.com







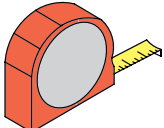
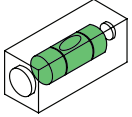

Installation Tools

The following tools may be required depending upon your particular installation. They are not included.

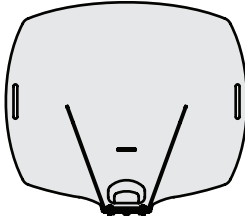
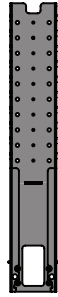
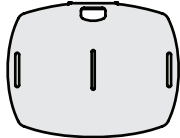
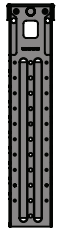
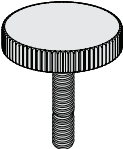
 #2 Phillips Tip Screwdriver	 Ladder
 Tape Measure	 Level

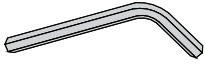
Parts List

Make sure your Premier Mounts product has the following hardware and components before beginning installation. If there are parts missing and/or damaged, stop the installation and call Premier Mounts at (800) 368-9700.

SHLF-VE Hardware			
 Large Shelf (Qty 1)	 Large Shelf Adjustable Bracket (Qty 1)	 Video Conference Shelf (Qty 1)	 Video Conference Shelf Adjustable Bracket (Qty 1)
 M6 x 20mm Knurl Knob (Qty 1)	 M6 x 8mm Pan Combo Screw (Qty 6)	 M6 x 12mm Set Screw (Qty 3)	 M3 Allen Wrench (Qty 1)
 Equipment Strap (Qty 1)	 1/4"-20 x 3/8" Pan Combo Phillips Screw (Qty 1)	 1/4" Flat Washers (Qty 3)	



Features

The A/V Shelving System for Low Profile Flat-Panel Mounts (SHLF-VE) is a versatile shelving system designed for Premier Mounts' P-Series mounts, one of the thinnest low profile flat-panel mounts on the market. The SHLF-VE is the perfect solution for mounting a video conferencing camera above the flat-panel display and "daisy-chaining" A/V equipment and/or computers below it.

Video Conferencing Camera Mounting Slot

The 3" slot is for mounting a wide variety of video conferencing cameras.

Simple Cable Management

The ultra-low profile barcket manages cables to improve the appearance of the display and equipment.

Ultra-Thin Brackets

Hook into the wall plate of a P-Series flat-panel mount at a maximum height of 48" to accommodate any common flat-panel size.

Security Strap Slots

Slots in the sides of the A/V shelves are designed for attaching straps to the equipment, if needed.

Daisy Chain

Attach additional large equipment shelves (SHLF-XE) (sold separately) by "daisy-chaining" them from the lowest equipment shelf.

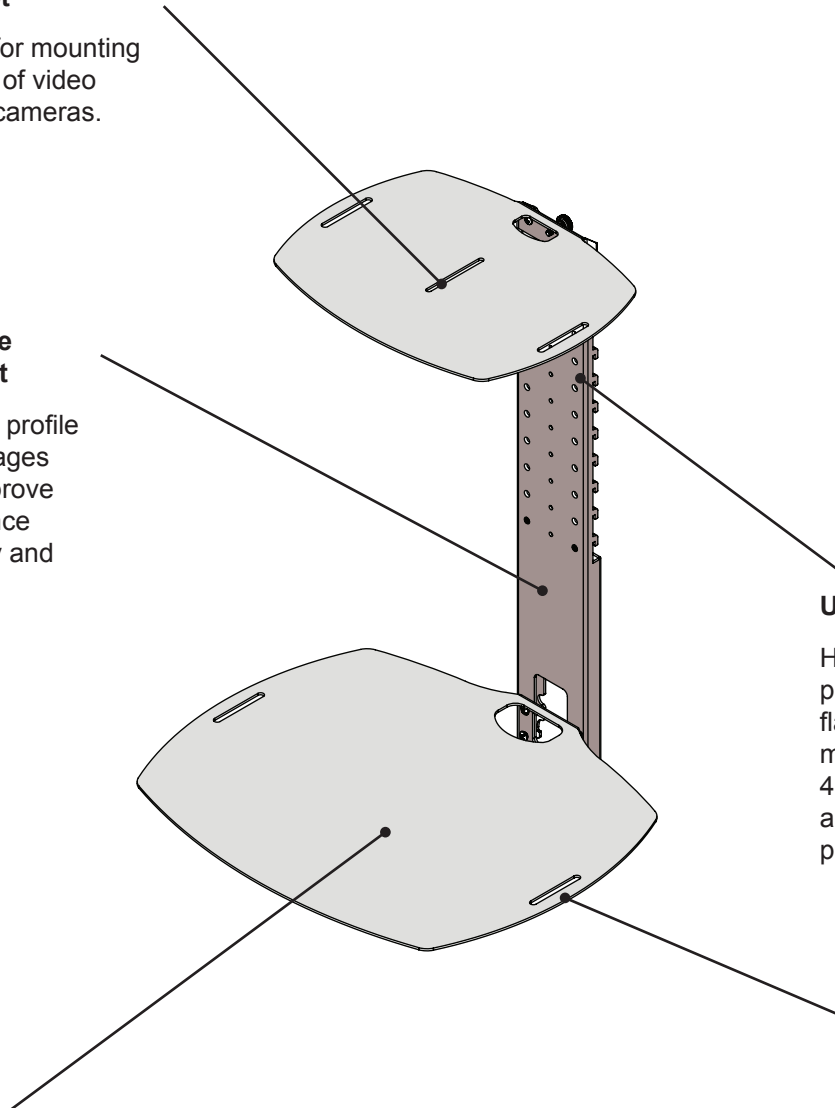



Installing the SHLF-VE

Introduction

The SHLF-VE shelving system is designed to easily hook into Premier Mounts' P-Series mounts. It permits the user to adjust each shelf in 10 increments of 1.3". This allows a maximum of 48" of vertical space between the top and lower shelves for the flat-panel and A/V equipment.

Please read through the safety instructions before installation. The P-Series mount must be attached to the wall without the flat-panel before installing the SHLF-VE.

Assembling the Video Conference Shelf

Step 1

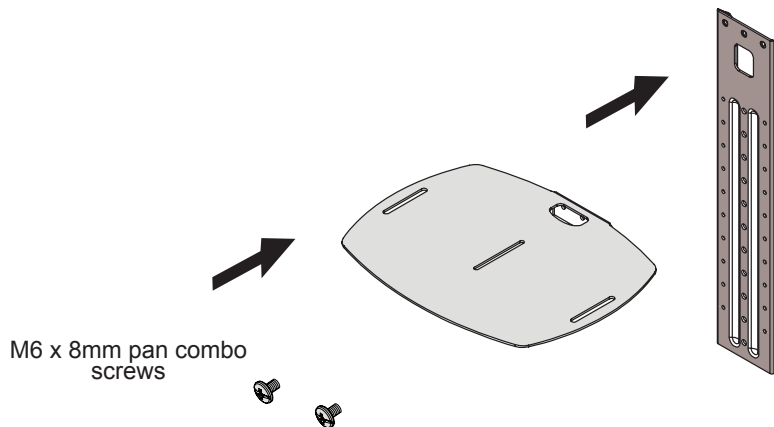

Use two (2) M6 x 8mm pan combo screws to fasten the video conference shelf to the video conference shelf adjustable bracket.



The screws should go in the top left and right screw holes of the video conference shelf adjustable bracket.

Step 2

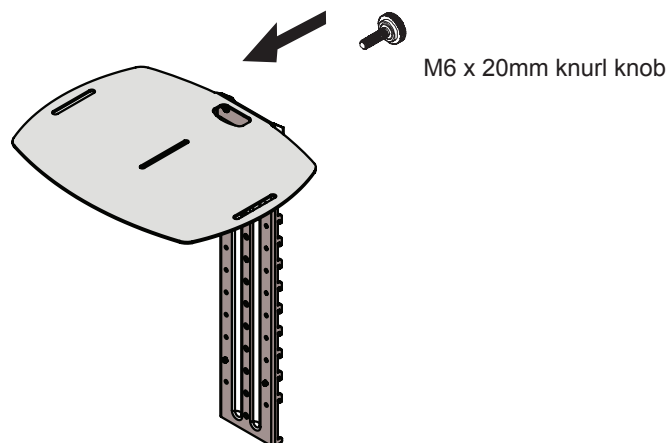

Attach one (1) M6 x 20mm knurl knob to the back of the video conference shelf assembly.



The knurl knob should go in the center pem nut in the back of the video conference shelf adjustable bracket. It will be used to balance and stabilize the video conference shelf assembly against the wall.



Attaching the Video Conference Shelf Assembly to a P-Series Mount

Step 1

P4263F mount shown for illustration purposes only.

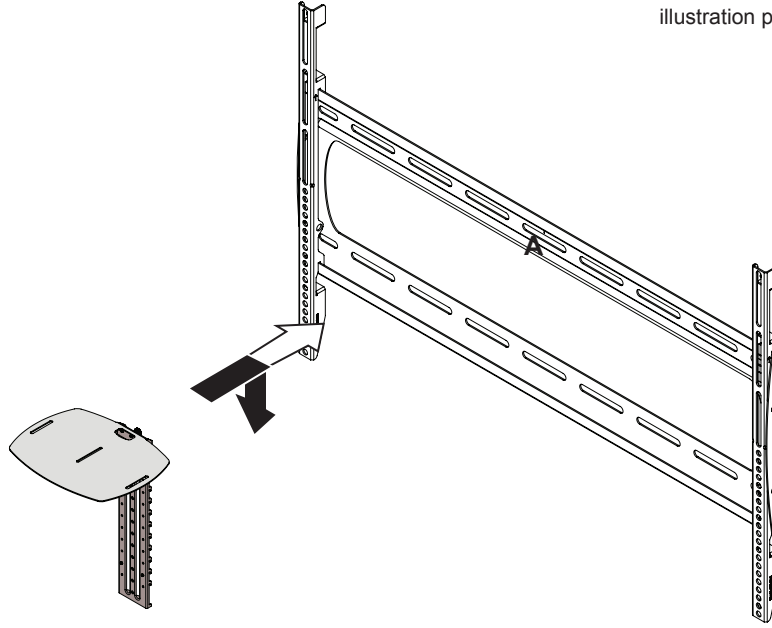

Hook the video conference shelf assembly at the desired height into the upper flange (A) of the P-Series mount.

Step 2

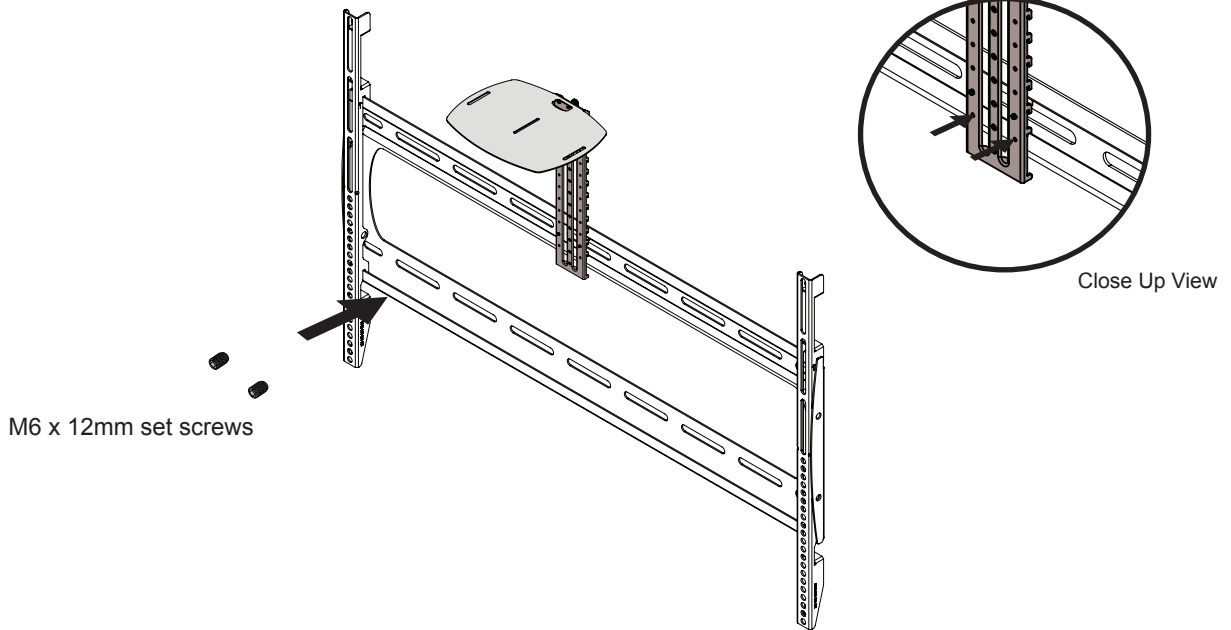

Use the M3 Allen wrench and two (2) M6 x 12mm set screws to tighten the video conference shelf assembly against the P-Series mount.



The set screws should go in the left and right screw holes of the video conference shelf adjustable bracket where the hooks are resting on the flange.



Step 3

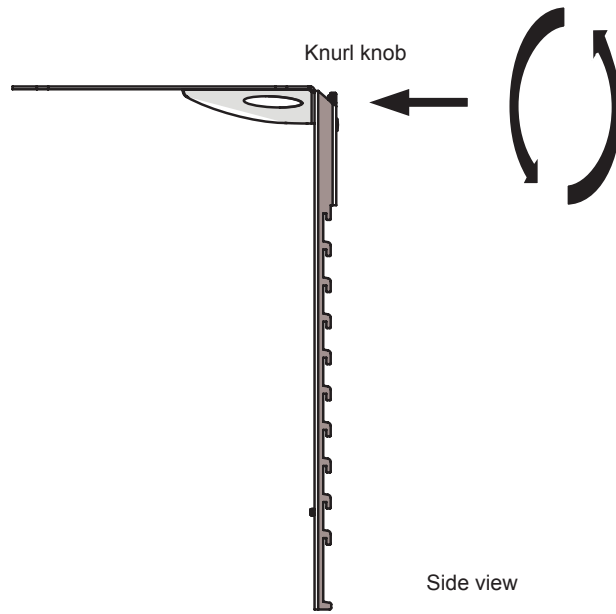

Adjust the knurl knob so that the video conference shelf is balanced and stabilized against the wall.



You may need to re-adjust the knurl knob again after attaching the video conferencing camera.

Attaching the Video Conferencing Camera

*Video conferencing camera shown for illustration purposes only.

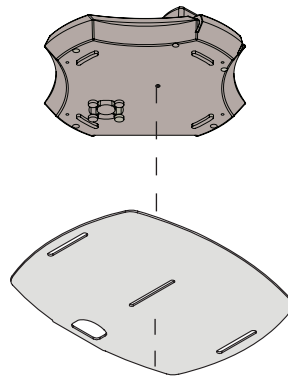

Bottom view of the video conference shelf. Adjustable bracket not shown.

1/4" flat washers
(use as needed)

1/4"-20 x 3/8" pan
combo screw



Use one (1) 1/4"-20 x 3/8" pan combo screw and 1/4" flat washers to attach the video conferencing camera to the video conference shelf assembly.



Large Shelf Assembly

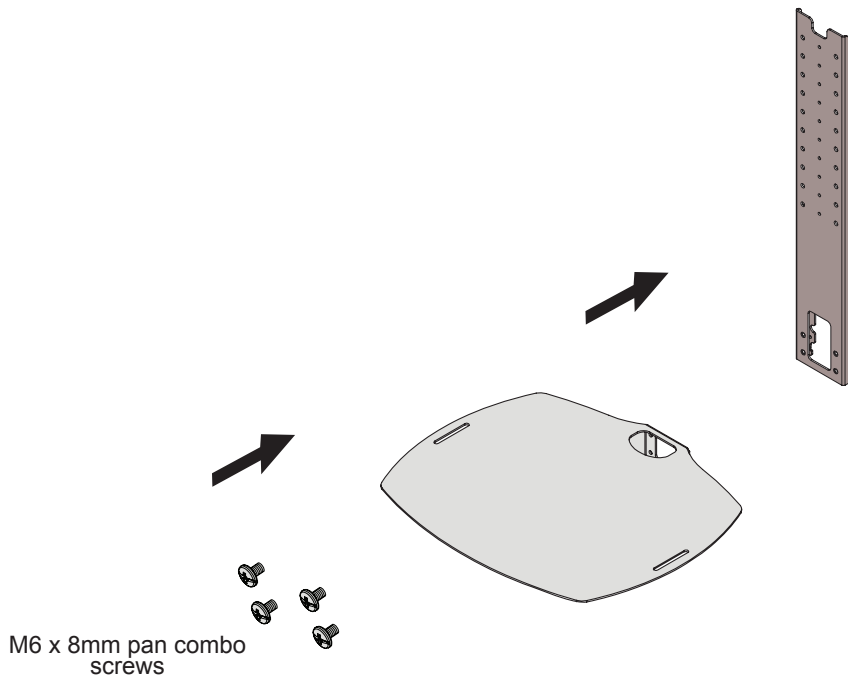

Use four (4) M6 x 8mm pan combo screws to fasten the large shelf to the large shelf adjustable bracket.

Attaching the Large Shelf Assembly to a P-Series Mount

Step 1

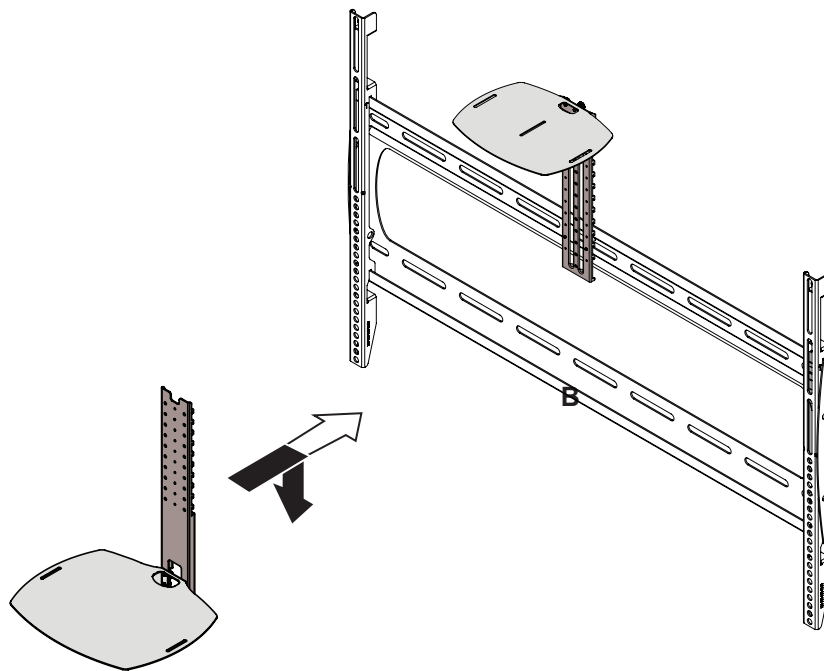

Hook the large shelf assembly at the desired height into the lower flange (B) of the P-Series mount.



Step 2

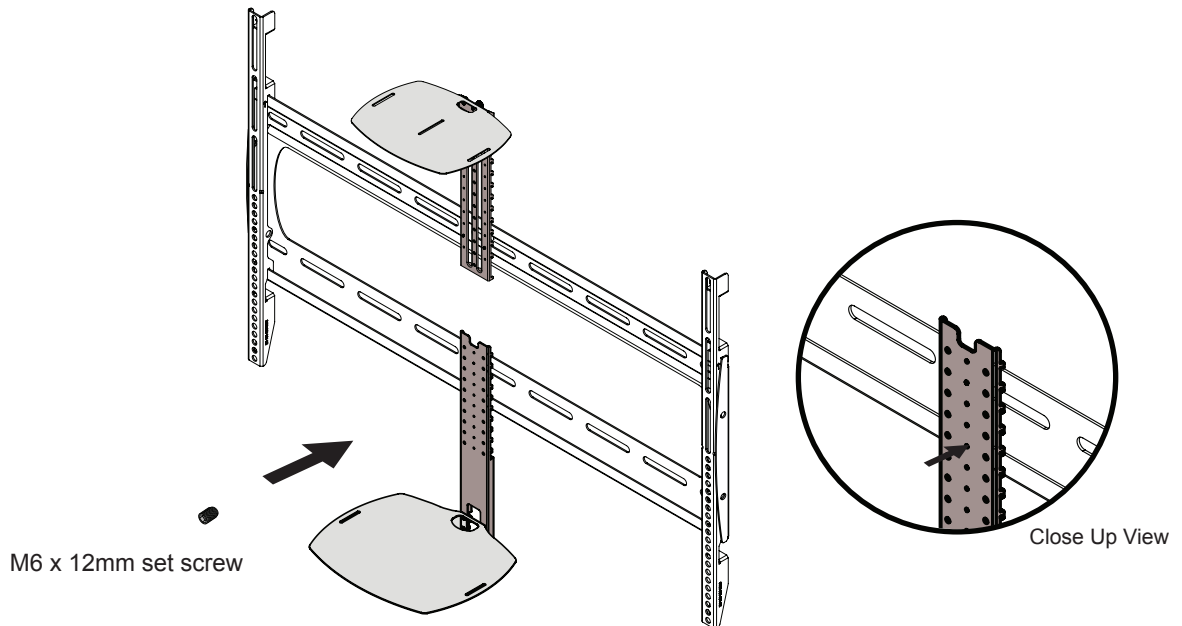

Use the M3 Allen wrench and one (1) M6 x 12mm set screw to tighten the large shelf assembly against the P-Series mount.

 The set screw should go in the center screw hole of the large shelf adjustable bracket where the hooks are resting on the flange.

Using the Equipment Strap

Step 1

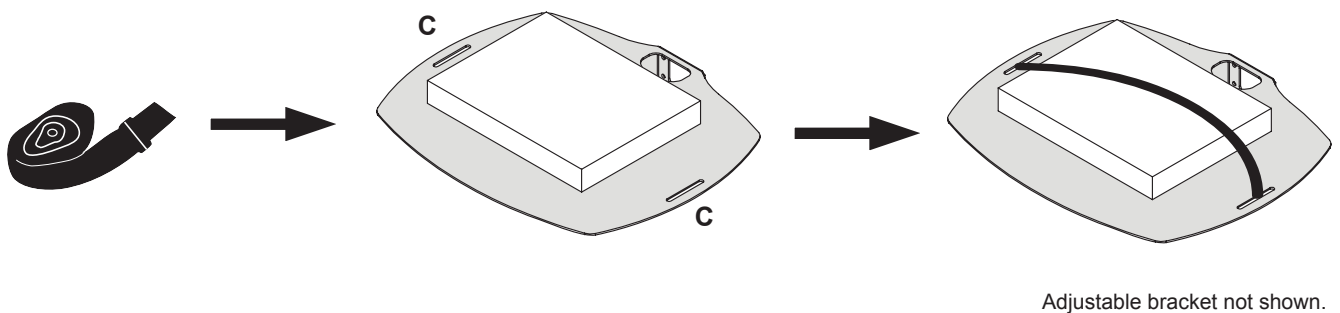

Insert the equipment strap through the shelf's side slots (C) and use it to keep the video conferencing camera or other equipment safely in place.



Attaching Additional Shelves (Optional)

Step 1

You can attach up to two (2) additional large shelves (SHLF-XE) to the large shelf assembly by “daisy-chaining” them. The SHLF-XE is sold separately.

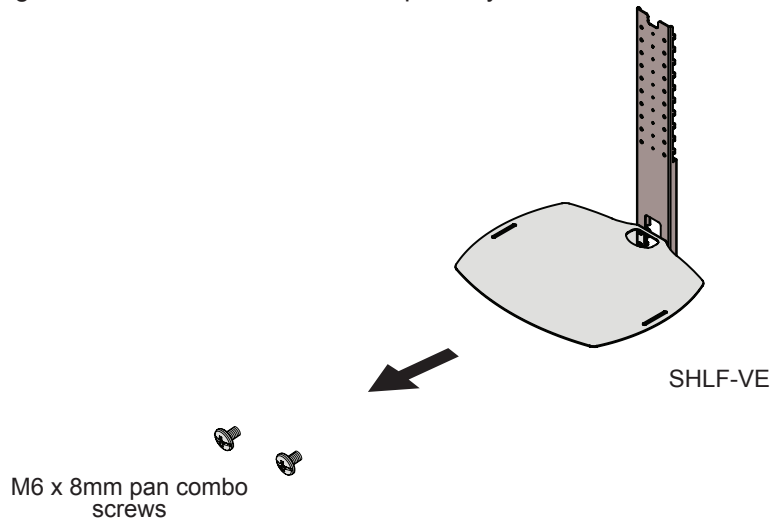

Remove the bottom two (2) M6 x 8mm pan combo screws from the first shelf in the large shelf assembly.

Step 2

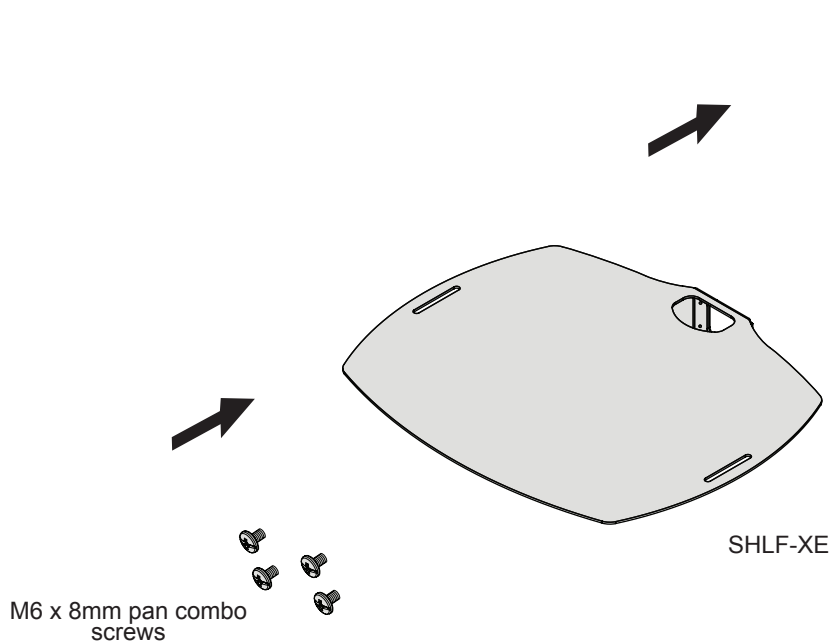

Use four (4) M6 x 8mm pan combo screws to fasten the additional large shelf to the shelf extension bracket.

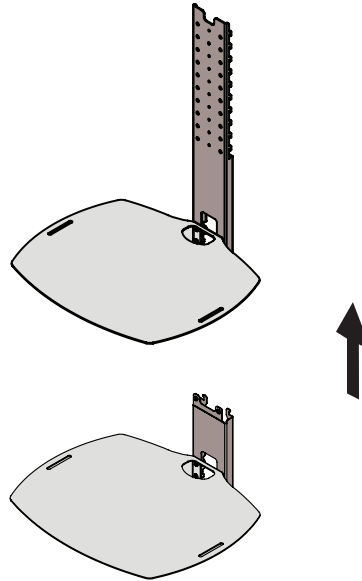
**Step 3**

Hook the additional shelf assembly to the bottom of the large shelf assembly.

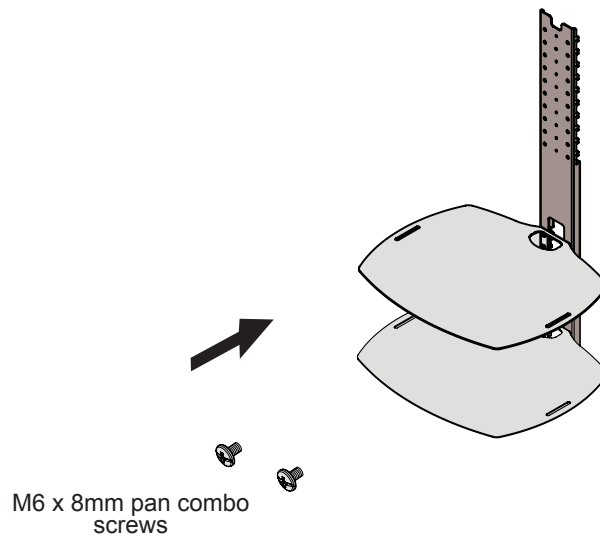
Step 4

Re-insert the bottom two (2) M6 x 8mm pan combo screws from Step 1 to fasten both assemblies together.

Step 5

Attach additional shelves by repeating Steps 1 to 4 (attach each additional shelf to the lowest shelf in the assembly).



Using Different Combos

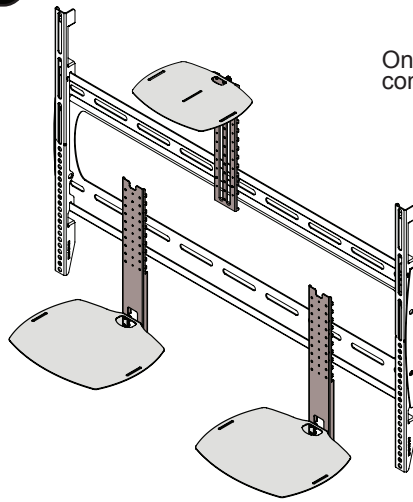

One example of a shelving system configuration.

Combine additional A/V shelf components in different configurations depending on your needs. Additional shelves are not included.

Technical Specifications

All measurements are in inches [mm].

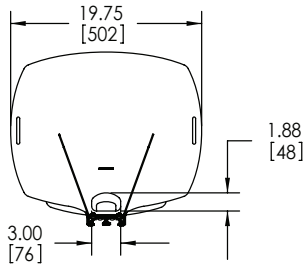
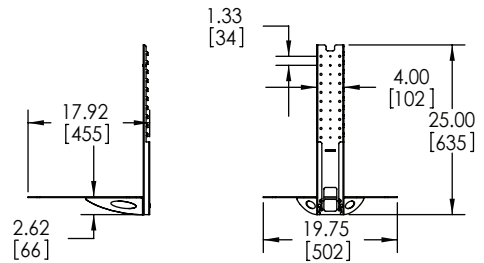
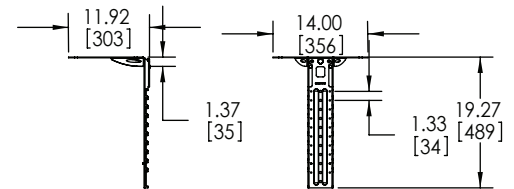
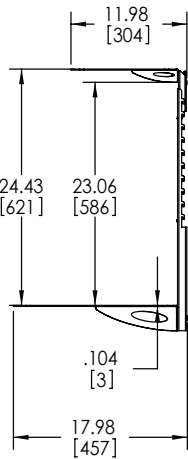
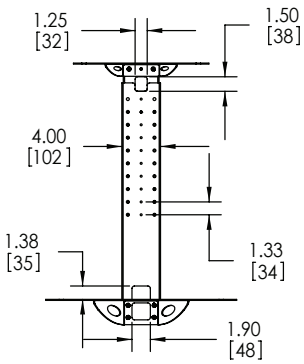
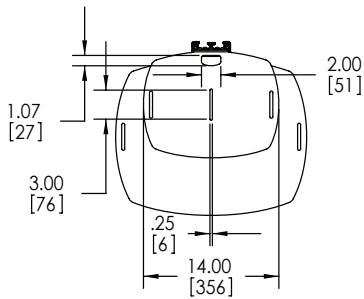



Warranty

PREMIER MOUNTS

LIMITED LIFETIME WARRANTY

What and Who is Covered by this Limited Warranty and for How Long

Premier Mounts warrants this product to be free from defects in material and workmanship for the lifetime of the original owner of this product. The limited warranty is valid only for the original purchaser of the product.

What Premier Mounts Will Do

At the sole option of Premier Mounts, Premier Mounts will repair or replace any product or product part that is defective. If Premier Mounts chooses to replace a defective product or part, a replacement product or part will be shipped to you at no charge, but you must pay any labor costs.

What is Not Covered; Limitations

PREMIER MOUNTS DISCLAIMS ANY LIABILITY FOR DAMAGE TO MOUNTS, ADAPTERS, DISPLAYS, PROJECTORS, OTHER PROPERTY, OR PERSONAL INJURY RESULTING, IN WHOLE OR IN PART, FROM IMPROPER INSTALLATION, MODIFICATION, USE OR MISUSE OF ITS PRODUCTS.

PREMIER MOUNTS DISCLAIMS ALL OTHER WARRANTIES, EXPRESS OR IMPLIED, INCLUDING WARRANTIES OF MERCHANTABILITY AND FITNESS FOR A PARTICULAR PURPOSE. PREMIER MOUNTS IS NOT RESPONSIBLE FOR INCIDENTAL OR CONSEQUENTIAL DAMAGES, INCLUDING BUT NOT LIMITED TO, INABILITY TO USE ITS PRODUCTS OR LABOR COSTS FOR REMOVING AND REPLACING DEFECTIVE PRODUCTS OR PARTS. SOME STATES DO NOT ALLOW THE EXCLUSION OR LIMITATION OF INCIDENTAL OR CONSEQUENTIAL DAMAGES, SO THE ABOVE LIMITATION OR EXCLUSION MAY NOT APPLY TO YOU.

What Customers Must Do for Limited Warranty Service

If you discover a problem that you think may be covered by the warranty you MUST REPORT it in writing to the address below within thirty (30) days. Proof of purchase (an original sales receipt) from the original consumer purchaser must accompany all warranty claims. Warranty claims must also include a description of the problem, the purchaser's name, address, and telephone number. General inquiries can be addressed to Premier Mounts Customer Service at 1-800-368-9700. Warranty claims will not be accepted over the phone or by fax.

Premier Mounts
Attn: Warranty Claim
3130 East Miraloma Ave.
Anaheim, CA 92806

How State Law Applies

THIS WARRANTY GIVES YOU SPECIFIC LEGAL RIGHTS, AND YOU MAY ALSO HAVE OTHER RIGHTS WHICH VARY FROM STATE TO STATE.

Disclaimer

Premier Mounts intends to make this manual accurate and complete. However, Premier Mounts makes no claim that the information contained herein covers all details, conditions or variations, nor does it provide for every possible contingency in connection with the installation or use of this product. The information contained in this document is subject to change without notice or obligation of any kind. Premier Mounts makes no representation of warranty, expressed or implied, regarding the information contained herein. Premier Mounts assumes no responsibility for accuracy, completeness or sufficiency of the information contained in this document.