

Introduction

The MM-HP15 is the 15" single pole for multi-monitor mounts with base for grommet hole installation. The MM-HP28 is the 28" version, and the MM-HP42 is the 42" version. These three different pole sizes provide more mounting options for those installing multi-monitor mounts. The larger the pole, the more displays that can be mounted per single base. The grommet hole base option installs on any tabletop with a standard 2 1/8" cable routing hole.

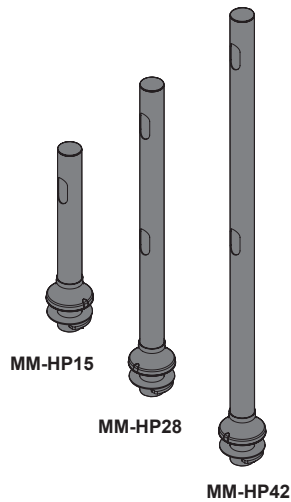

Parts List

 15"	 28"	 42"	 Horseshoe Locking Plate (Qty 1)
 MM-HP15/28/42 (Varied sized pole with cable routing hole) (Qty 1)			 Stabilizing Steel Ring (Qty 1)
			 Plastic Tube Cover (Qty 1)
			 M6 x 20mm Combo Screw (Qty 3)

Step 1

Multi-monitor mounts with grommet hole bases easily install on any tabletop with a standard 2 1/8" cable routing hole.

First, determine where you would like your multi-monitor mount positioned on your desired surface. The mounting surface should be capable of supporting 5x the weight of the flat-panel and mount. (Mount sold separately)

? Are you installing your pole to a surface with a pre-existing grommet hole?

If yes, proceed to step 2...

If no, follow instructions below

Recommended tool for next step is a hole saw
(Not larger than 2 1/4") See figure 1 for example.

1. Drill a hole no larger than 2 1/4" though the desired surface with your hole saw.

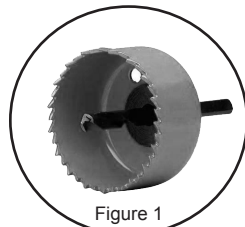
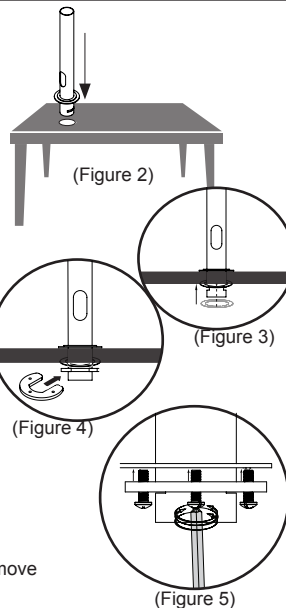

Figure 1

Step 2

1. Position your pole above the hole and place the pole through the hole until the welded steel ring is resting on the surface (Figure 2).
2. Slide the stabilizing steel ring up the bottom of the tube from below your installation surface (Figure 3).
3. Slide the horseshoe locking plate through the keyways on the bottom of the tube below the table (Figure 4).
4. Insert the (3) M6 x 20mm combination screws through the holes visible on the bottom of the horseshoe locking plate.
5. Screw them in until they are pressing the stabilizing ring tightly to the surface.



(Figure 2)

(Figure 3)

(Figure 4)

(Figure 5)

! Test the stability of the pole by trying to move it. It should remain sturdy and hold tight.

Step 3

Once you have made certain that the pole is secure to the surface

1. Slide the plastic tube cover over the top of the now secure pole.
2. The cover should be moved to the surface of the table to conceal the welded steel ring and the cable routing hole to provide a clean and finished appearance.

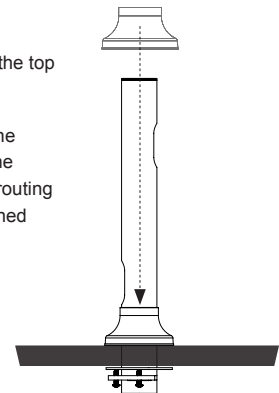

PREMIER MOUNTS

LIMITED LIFETIME WARRANTY

What and Who is Covered by this Limited Warranty and for How Long

Premier Mounts warrants this product to be free from defects in material and workmanship for the lifetime of the original owner of this product. The limited warranty is valid only for the original purchaser of the product.

What Premier Mounts Will Do

At the sole option of Premier Mounts, Premier Mounts will repair or replace any product or product part that is defective. If Premier Mounts chooses to replace a defective product or part, a replacement product or part will be shipped to you at no charge, but you must pay any labor costs.

What is Not Covered; Limitations

PREMIER MOUNTS DISCLAIMS ANY LIABILITY FOR DAMAGE TO MOUNTS, ADAPTERS, DISPLAYS, PROJECTORS, OTHER PROPERTY, OR PERSONAL INJURY RESULTING, IN WHOLE OR IN PART, FROM IMPROPER INSTALLATION, MODIFICATION, USE OR MISUSE OF ITS PRODUCTS. PREMIER MOUNTS DISCLAIMS ALL OTHER WARRANTIES, EXPRESS OR IMPLIED, INCLUDING WARRANTIES OF MERCHANTABILITY AND FITNESS FOR A PARTICULAR PURPOSE. PREMIER MOUNTS IS NOT RESPONSIBLE FOR INCIDENTAL OR CONSEQUENTIAL DAMAGES, INCLUDING BUT NOT LIMITED TO, INABILITY TO USE ITS PRODUCTS OR LABOR COSTS FOR REMOVING AND REPLACING DEFECTIVE PRODUCTS OR PARTS. SOME STATES DO NOT ALLOW THE EXCLUSION OR LIMITATION OF INCIDENTAL OR CONSEQUENTIAL DAMAGES, SO THE ABOVE LIMITATION OR EXCLUSION MAY NOT APPLY TO YOU.

What Customers Must Do for Limited Warranty Service

If you discover a problem that you think may be covered by the warranty you MUST REPORT it in writing to the address below within thirty (30) days. Proof of purchase (an original sales receipt) from the original consumer purchaser must accompany all warranty claims. Warranty claims must also include a description of the problem, the purchaser's name, address, and telephone number. General inquiries can be addressed to Premier Mounts Customer Service at 1-800-368-9700. Warranty claims will not be accepted over the phone or by fax.

Premier Mounts
Attn: Warranty Claim
3130 East Miraloma Ave.
Anaheim, CA 92806

How State Law Applies

THIS WARRANTY GIVES YOU SPECIFIC LEGAL RIGHTS, AND YOU MAY ALSO HAVE OTHER RIGHTS WHICH VARY FROM STATE TO STATE.

Introduction

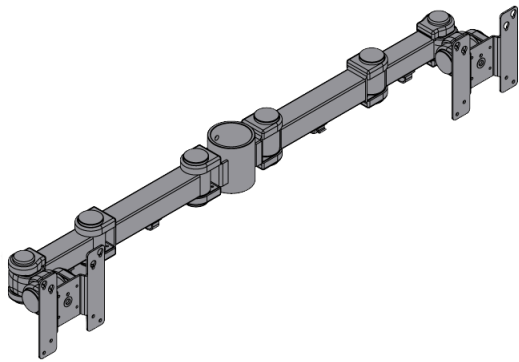

The MM-A2 is a dual articulating multimonitor mount arm that works with any 2" tube. Each mounting head provides 90° of omnidirectional tilt. The mounting heads include both 75x75mm and 100x100mm VESA mounting patterns. The arm includes integrated cable management tabs to keep wires and cables protected and organized.

Step 1

- Slide your mounting arm over the pole and base (Figure 1) (not included, but should be previously installed).
- Determine the position on the pole desired for your mounting arm.
- Once in desired position, tighten the two (2) pre-installed M8 x 6mm set screws in the holes in the back of the MM-A2. Tighten with included allen key (Figure 2).

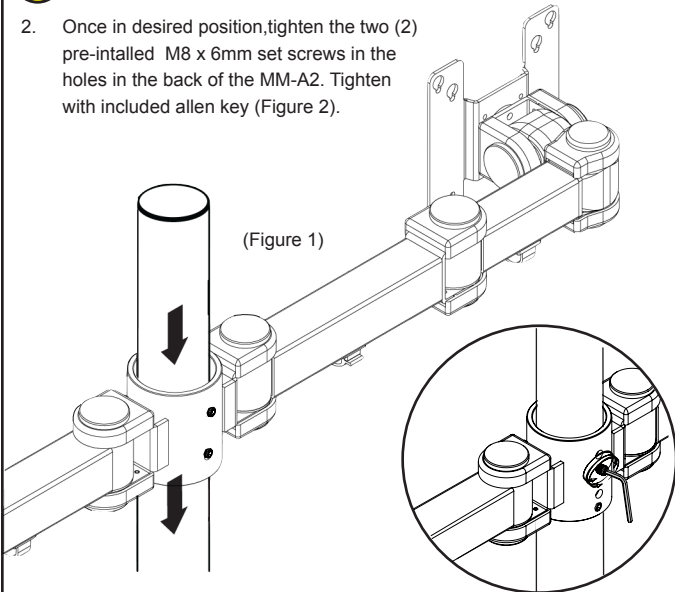

Step 2

Are you installing to a 75x75mm or 100x100mm VESA mounting pattern?

For 75x75mm, use mounting points A. For 100x100mm use points B in figure 3.

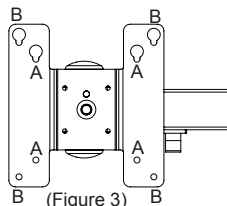

- Thread the M4 screws to one-half of their length into the top two mounting holes on each display, but do not tighten the M4 screws at this time.

Parts List

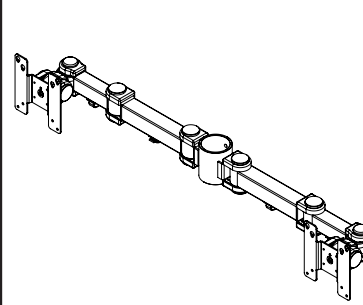

MM-A2
Dual Articulating Mounting Arm
(Qty 1)

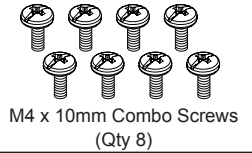

M4 x 10mm Combo Screws
(Qty 8)

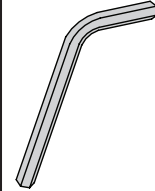

6mm Allen Key
(Qty 1)

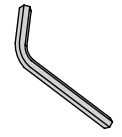

5/32" Allen Key
(Qty 1)

Step 3

- Insert the heads of the M4 screws through the keyhole slots on the mounting head (Figure 5).
- Insert the remaining two (2) M4x10mm screws, into the bottom mounting points (Figure 4)
- Repeat sub-steps 1 & 2 for the second display.
- Tighten all M4 screws.



Do not overtighten the mounting hardware

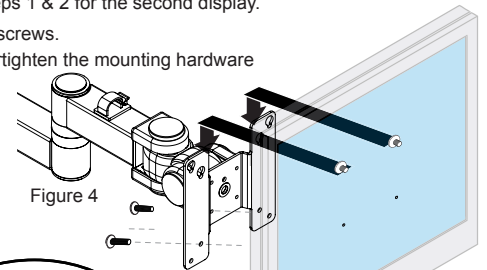
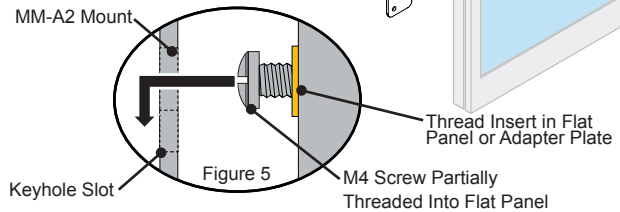

Figure 4



MM-A2 Mount

Thread Insert in Flat Panel or Adapter Plate

Figure 5

M4 Screw Partially Threaded Into Flat Panel

Step 3

To adjust the tension and/or tilt angle of the mounting head:

- Adjust the mounting head by utilizing the 90° continuous tilt, until it is in the desired position.
- Remove the side and bottom cosmetic caps from the mounting head (Figure 6)
- Use the supplied 6mm allen wrench to tighten the allen screws on the head.
- The side 6mm screw secures the tilt position (Point A), while the bottom 6mm screw secures the pivot (Point B).



Do not overtighten the mounting hardware

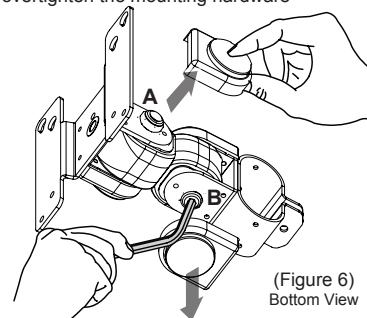

(Figure 6)
Bottom View

PREMIER MOUNTS

LIMITED LIFETIME WARRANTY

What and Who is Covered by this Limited Warranty and for How Long

Premier Mounts warrants this product to be free from defects in material and workmanship for the lifetime of the original owner of this product. The limited warranty is valid only for the original purchaser of the product.

What Premier Mounts Will Do

At the sole option of Premier Mounts, Premier Mounts will repair or replace any product or product part that is defective. If Premier Mounts chooses to replace a defective product or part, a replacement product or part will be shipped to you at no charge, but you must pay any labor costs.

What is Not Covered; Limitations

PREMIER MOUNTS DISCLAIMS ANY LIABILITY FOR DAMAGE TO MOUNTS, ADAPTERS, DISPLAYS, PROJECTORS, OTHER PROPERTY, OR PERSONAL INJURY RESULTING, IN WHOLE OR IN PART, FROM IMPROPER INSTALLATION, MODIFICATION, USE OR MISUSE OF ITS PRODUCTS. PREMIER MOUNTS DISCLAIMS ALL OTHER WARRANTIES, EXPRESS OR IMPLIED, INCLUDING WARRANTIES OF MERCHANTABILITY AND FITNESS FOR A PARTICULAR PURPOSE. PREMIER MOUNTS IS NOT RESPONSIBLE FOR INCIDENTAL OR CONSEQUENTIAL DAMAGES, INCLUDING BUT NOT LIMITED TO, INABILITY TO USE ITS PRODUCTS OR LABOR COSTS FOR REMOVING AND REPLACING DEFECTIVE PRODUCTS OR PARTS. SOME STATES DO NOT ALLOW THE EXCLUSION OR LIMITATION OF INCIDENTAL OR CONSEQUENTIAL DAMAGES, SO THE ABOVE LIMITATION OR EXCLUSION MAY NOT APPLY TO YOU.

What Customers Must Do for Limited Warranty Service

If you discover a problem that you think may be covered by the warranty you **MUST REPORT** it in writing to the address below within thirty (30) days. Proof of purchase (an original sales receipt) from the original consumer purchaser must accompany all warranty claims. Warranty claims must also include a description of the problem, the purchaser's name, address, and telephone number. General inquiries can be addressed to Premier Mounts Customer Service at 1-800-368-9700. Warranty claims will not be accepted over the phone or by fax.

Premier Mounts
Attn: Warranty Claim
3130 East Miraloma Ave.
Anaheim, CA 92806

How State Law Applies

THIS WARRANTY GIVES YOU SPECIFIC LEGAL RIGHTS, AND YOU MAY ALSO HAVE OTHER RIGHTS WHICH VARY FROM STATE TO STATE.