

## INSTALLATION INSTRUCTIONS

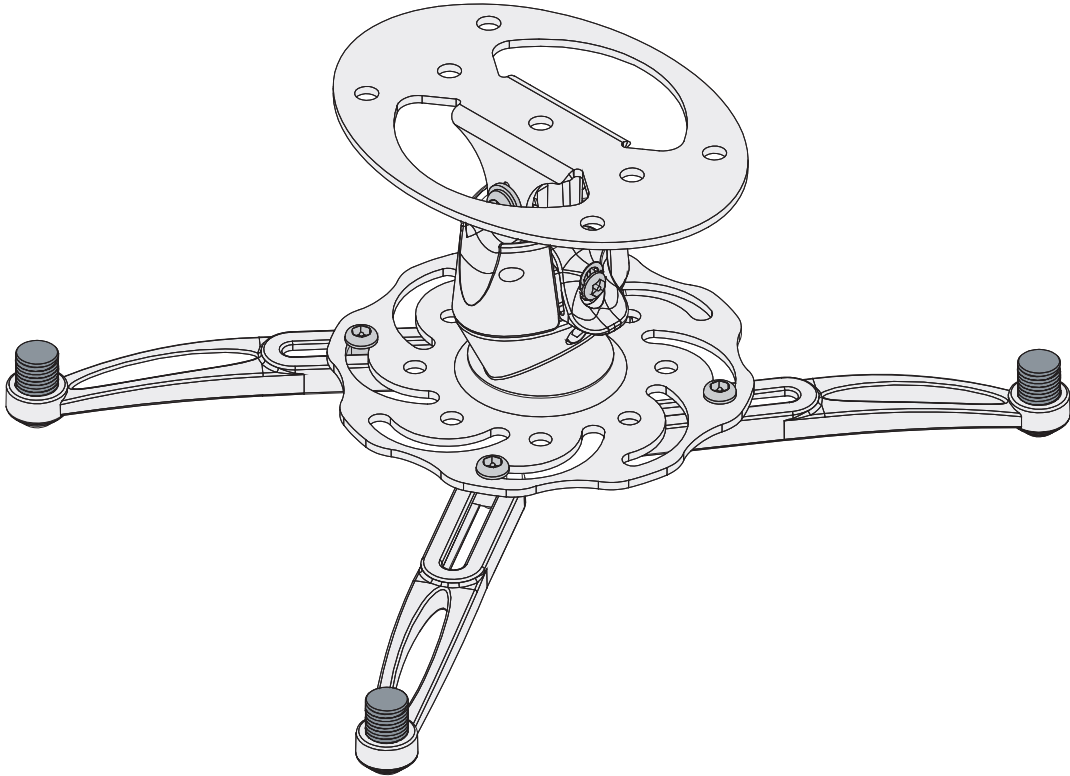

**Polaris™  
Universal Projector Mount**  
Model: MAG

---

**NORTH AMERICA**

3130 East Miraloma Avenue  
Anaheim, CA 92806 USA  
USA and Canada  
Phone: 1.800.368.9700  
Fax: 1.800.832.4888  
Other Locations  
Phone: (001).714.632.7100  
Fax: (001).714.632.1044

**EUROPE**

Swallow House,  
Shilton Industrial Estate,  
Shilton, Coventry, England CV79JY  
Phone: +44 (0) 2476 614700  
Fax: +44 (0) 2476 614710



## Contents

Weight Limit.....	2
Warning Statements.....	2
Installation Tools.....	3
Parts List.....	3
Features.....	4
Attaching the MAG Mount to the Projector.....	5
Attaching the Projector Plate.....	5
Selecting the Mounting Hardware.....	5
Securing the MAG Projector.....	6
Multiple Mounting Point Installation.....	7
Single Mounting Point Installation.....	9
Installing the MAG Mount.....	10
Wood Stud Installation.....	10
Solid Surface Installation.....	11
MAG Mount Adjustment.....	11
Technical Specifications.....	12
Warranty.....	13
Disclaimer.....	13

## Weight Limit

Maximum Projector Weight: **25 lbs.**

THE CEILING STRUCTURE MUST BE CAPABLE OF SUPPORTING AT LEAST FIVE TIMES THE WEIGHT OF THE PROJECTOR. IF NOT, THE CEILING STRUCTURE MUST BE REINFORCED.

## Warning Statements



PRIOR TO THE INSTALLATION OF THIS PRODUCT, THE INSTALLATION INSTRUCTIONS MUST BE READ AND COMPLETELY UNDERSTOOD. KEEP THESE INSTALLATION INSTRUCTIONS IN AN EASILY ACCESSIBLE LOCATION FOR FUTURE REFERENCE.



PROPER INSTALLATION PROCEDURE BY A QUALIFIED SERVICE TECHNICIAN MUST BE FOLLOWED, AS OUTLINED IN THESE INSTALLATION INSTRUCTIONS. FAILURE TO DO SO COULD RESULT IN PROPERTY DAMAGE, SERIOUS PERSONAL INJURY, OR EVEN DEATH.



SAFETY MEASURES MUST BE PRACTICED AT ALL TIMES DURING THE ASSEMBLY OF THIS PRODUCT. USE PROPER SAFETY EQUIPMENT AND TOOLS FOR THE ASSEMBLY PROCEDURE TO PREVENT PERSONAL INJURY.



PREMIER MOUNTS DOES NOT WARRANT AGAINST DAMAGE CAUSED BY THE USE OF ANY PREMIER MOUNTS PRODUCT FOR PURPOSES OTHER THAN THOSE FOR WHICH IT WAS DESIGNED OR DAMAGE CAUSED BY UNAUTHORIZED ATTACHMENTS OR MODIFICATIONS, AND IS NOT RESPONSIBLE FOR ANY DAMAGES, CLAIMS, DEMANDS, SUITS, ACTIONS OR CAUSES OF ACTION OF WHATEVER KIND RESULTING FROM, ARISING OUT OF OR IN ANY MANNER RELATING TO ANY SUCH USE, ATTACHMENTS OR MODIFICATIONS.



At least two qualified people should perform the assembly procedure. Personal injury and/or property damage can result from dropping or mishandling the projector.



If mounting to wall studs or ceiling studs, make sure that the mounting screws are anchored into the center of the wall studs or ceiling studs. Use of an edge-to-edge stud finder is recommended.



Be aware of the mounting environment. If drilling and/or cutting into the mounting surface, always make sure that there are no electrical wires in wall. Cutting or drilling into an electrical line may cause serious personal injury.



Make sure there are no water or natural gas lines inside the wall where the mount is to be located. Cutting or drilling into a water or gas line may cause severe property damage or personal injury.



This product is intended for indoor use only. Use of this product outdoors could lead to product failure and/or serious personal injury.



Do not install near sources of high heat. Do not install on a structure that is prone to vibration, movement or chance of impact.









Contact Premier Mounts with any questions:  
(800) 368-9700  
techsupport@mounts.com

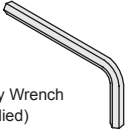

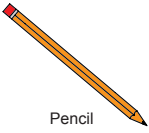

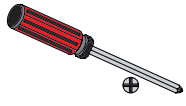
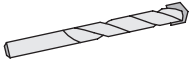

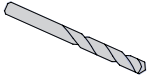
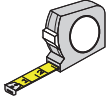



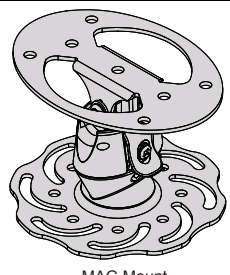
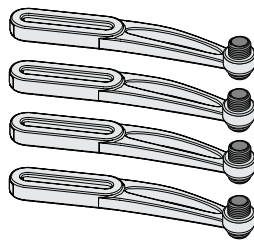
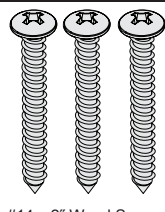
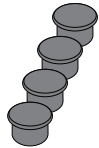

## Installation Tools

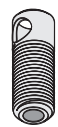
The following tools may be required depending upon your particular installation. They are not included.

 M5 Security Wrench (Supplied)	 Power Drill	 Pencil	 Protective Eyewear	 Phillips Tip Screwdriver
 Masonry Drill Bit	 Ladder	 1/8" Wood Drill Bit	 Tape Measure	

## Parts List

Make sure your Premier Mounts product has the following hardware and components before beginning installation. If there are parts missing and/or damaged, stop the installation and call Premier Mounts at (800) 368-9700.

MAG Mount Hardware			
 MAG Mount (Qty 1)		 Mounting Leg (Qty 4)	
 #14 x 2" Wood Screw (Qty 3)	 Barrel Cap (Qty 4)	 Star Washers (Qty 2)	 Security Leveling Barrel (Qty 1)
Lock-It™ Security Hardware			
 M3 Flat Washer (Qty 4)	 1/4-20 x 5/16" Screw (Qty 1)	 M2.5 x 8mm Screw (Qty 4)	 M2.5 x 10mm Screw (Qty 4)
 M3 x 16mm Screw (Qty 4)	 M4 x 12mm Screw (Qty 6)	 M5 x 12mm Screw (Qty 4)	 M6 x 12mm Screw (Qty 8)



## Features

Congratulations on the purchase of your new Premier Mounts Polaris™ Universal Projector Mount. Your MAG Mount may be secured to either a single ceiling stud or a solid surface ceiling, such as concrete. The Polaris™ features our exclusive MagnaGuide™ Technology which assists the installer for quicker installation times and peace of mind.

Please read these installation instructions once thoroughly before attempting to install your Premier Mounts product.

Please take a minute to familiarize yourself with the contents of the package and make sure you have all the parts and tools you need to safely complete the installation.

In addition, some steps of this installation may require two people to prevent personal injury and/or damage to your projector. Please observe all warnings in the following installation procedure and utilize proper safety equipment at all times.

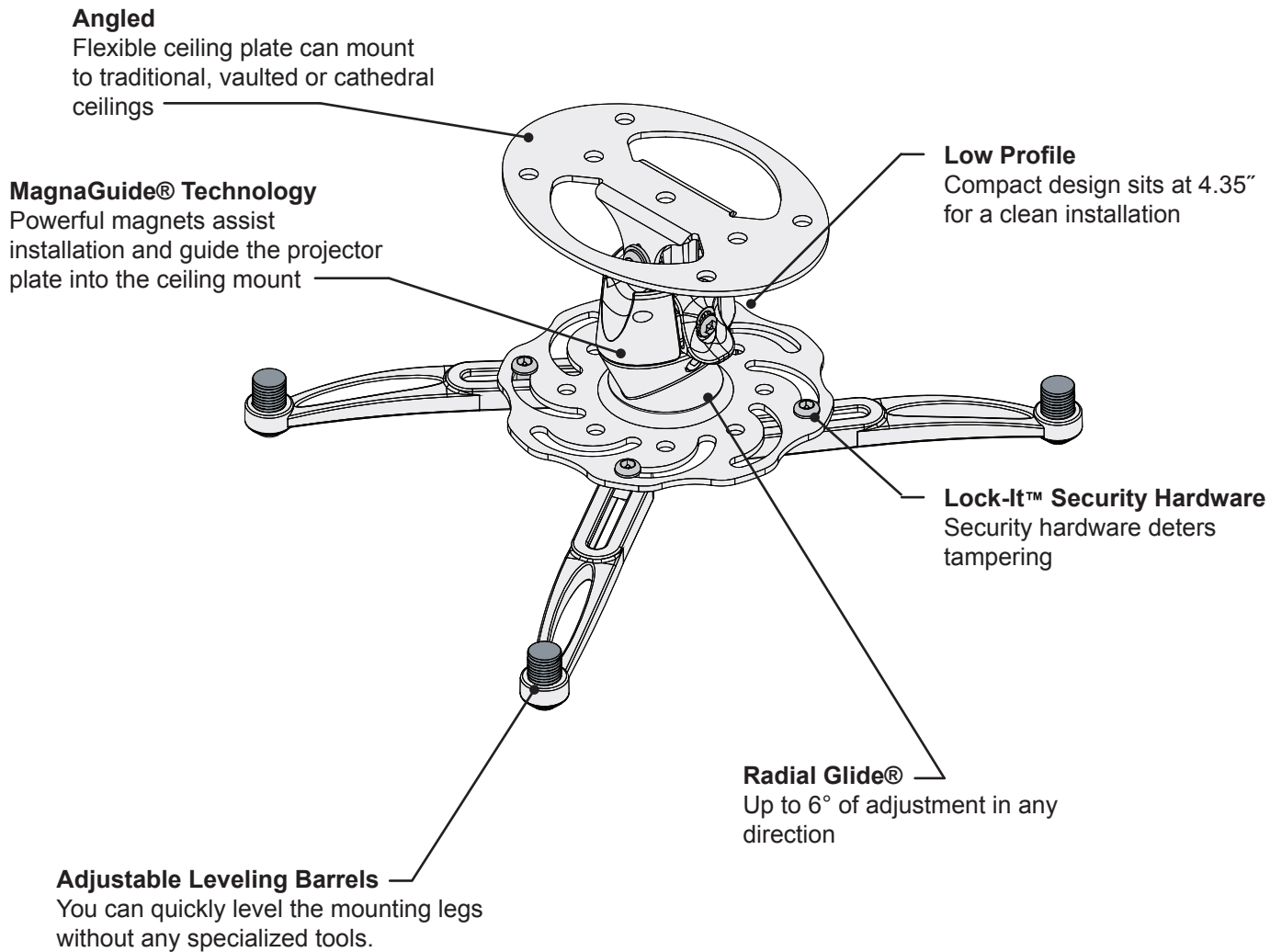



## Attaching the MAG Mount to the Projector

- 1 Locate the mounting points on the bottom of the projector (see arrows to the left).

Proceed to the “Attaching the Projector Plate” section.

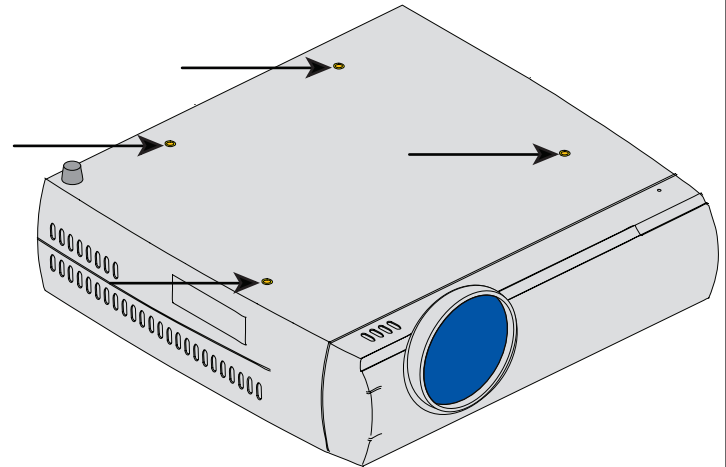

## Attaching the Projector Plate

### Selecting the Mounting Hardware

- 1 Insert a small straw or toothpick into the thread inserts found on the bottom or top of the projector.
- 2 Use a pencil to mark the depth of the thread insert on the small straw or toothpick, as shown in Figure 1.
- 3 Insert the small straw or toothpick into the remaining thread inserts to compare and verify their depth.
- 4 Locate the correct diameter screw for the thread insert.

If the screw you selected is longer than the mark on the small straw or toothpick, as shown in Figure 2 and Figure 3, do not use this screw. The screw length must not bypass the mark.

- 5 Test each size of the screws provided.

The correct screws should thread easily into the mounting point and not pull out when tension is applied.

- ?** Does your projector have multiple mounting points or a single mounting point?

### Lock-It™ Security Hardware Pack (Optional)

The MAG Mount comes with the option of using Lock-It™ Security Screws. To use the security screws, simply replace the M6 x 12mm Phillips Pan head screws with the M6 x 12mm security screws. Once the hardware has been changed, adjust the MAG Mount and tighten down the M6 x 12mm security screws using the M5 Security Allen wrench (supplied).

If your projector has multiple mounting points, proceed to the “Multiple Mounting Point Installation” section.

If your projector has a single mounting point, skip to the “Single Mounting Point Installation” section.

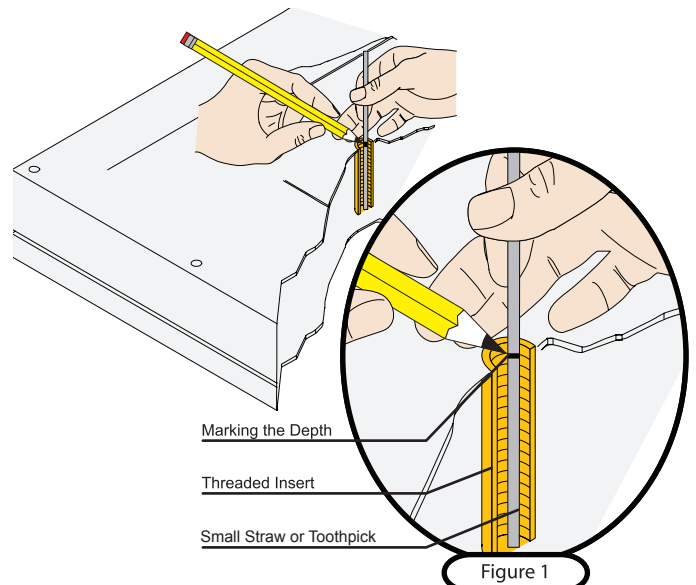

Figure 1

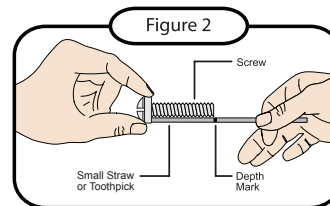

Figure 2

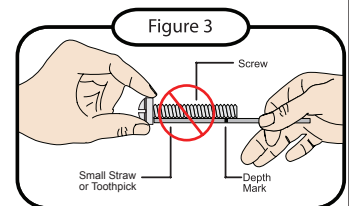
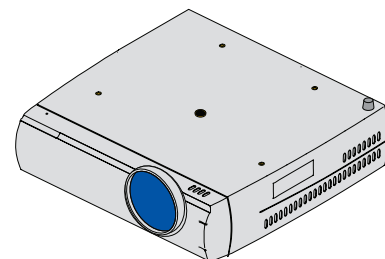

Figure 3





## Securing the MAG Projector

Your MAG Projector Mount includes one (1) Security Barrel which can provide additional theft deterrence for your projector.

Shown below are two examples of how you can use the security barrel to make your projector installation more secure: the PCB-CSL1 Security Cable (sold separately) or padlock (combination or keyed; sold separately). Follow the instructions below to install and secure the security barrel.

If you choose not to install the security barrel, please proceed to the **“Multiple Mounting Point Installation”** section.

If you choose to install the security barrel, please follow the instructions outlined below.

- 1 Determine which leveling barrel will be removed.
- 2 Remove the mounting screw.
- 3 Remove the leveling barrel by turning the leveling barrel counter-clockwise.
- 4 Thread in the security barrel clockwise.
- 5 Insert and tighten the mounting screw.
- 6 Attach theft deterrent device (PCB-CSL1 or padlock) through the hole that is on the security barrel.

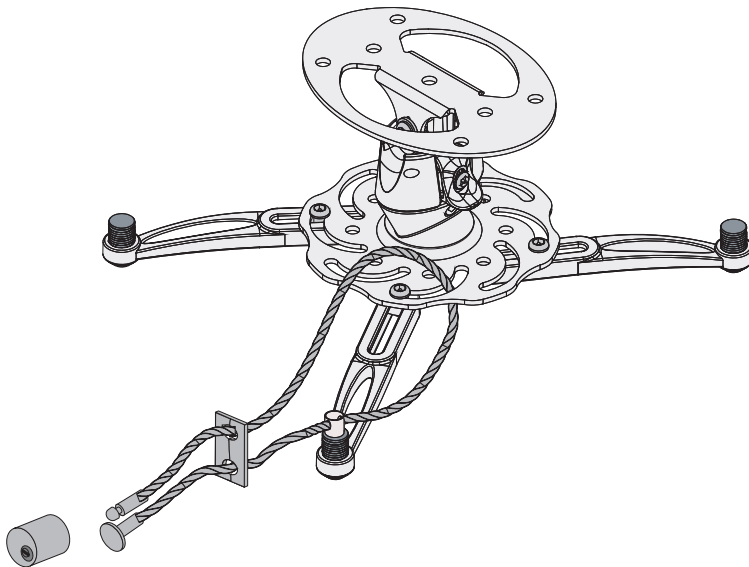

PCB-CSL1

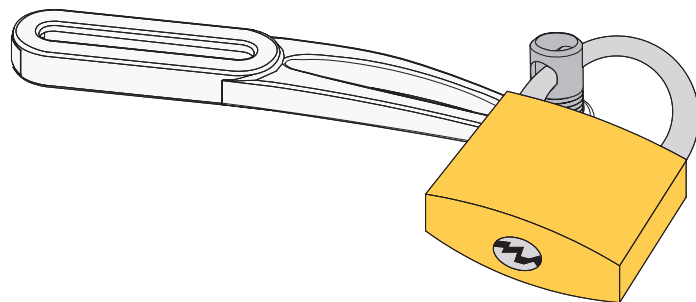

Padlock  
(Combination or Keyed)

## Multiple Mounting Point Installation

### Step 1

- 1 Locate the projector's mounting points.
- 2 Position an appropriate number of mounting legs on the projector.

You can use any combination of three (3) or more mounting legs, depending on the number and location of the thread inserts on your projector.



The number and placement of mounting points on projectors varies between projector manufacturers. Refer to your projector's technical specifications for the number and location of the mounting points on your specific projector.



Shown with optional security barrel installed.

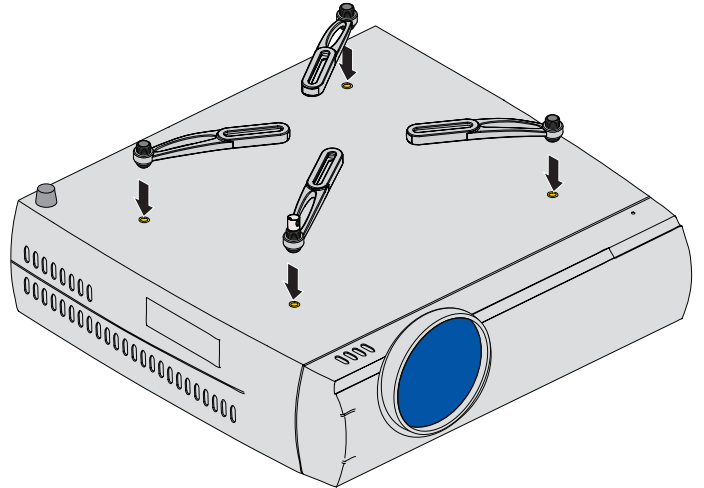

### Step 2



Only attach to the projector manufacturer's specified mounting points on the projector chassis with a minimum three mounting legs. Please follow all safety instructions specified by the projector manufacturer as well as the safety instructions outlined in this manual.



Depending on your application, the long mounting legs and the short mounting legs may be used together. There are multiple configurations that may be used combining the long mounting legs with the short mounting legs.

- 1 Attach the appropriate number of mounting legs to the projector using the corresponding mounting hardware.



Do not tighten the mounting hardware at this time.

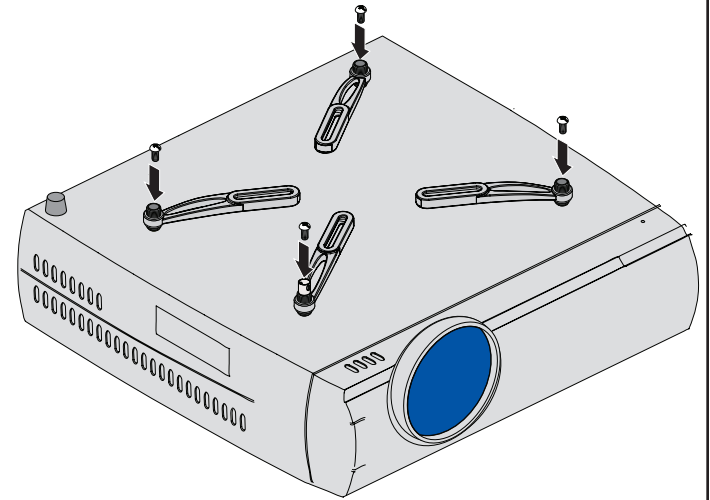

### Step 3

- 1 If the mounting legs need to be leveled, rotate the leveling barrels to level the mounting bracket.
  - 2 To raise the mounting legs, rotate the leveling barrel clockwise. To lower the mounting leg, rotate the leveling barrel counter clockwise.
-  Raise or lower each of the mounting legs, by rotating the leveling barrels, until all of the mounting legs are at an equal height.
- Lower the mounting leg by rotating the leveling barrel counter-clockwise.
  - Raise the mounting legs by rotating the leveling barrel clockwise.
- 3 When the desired position is achieved, tighten the mounting screws to the projector and then tighten the hex head screws with the M5 Allen wrench.

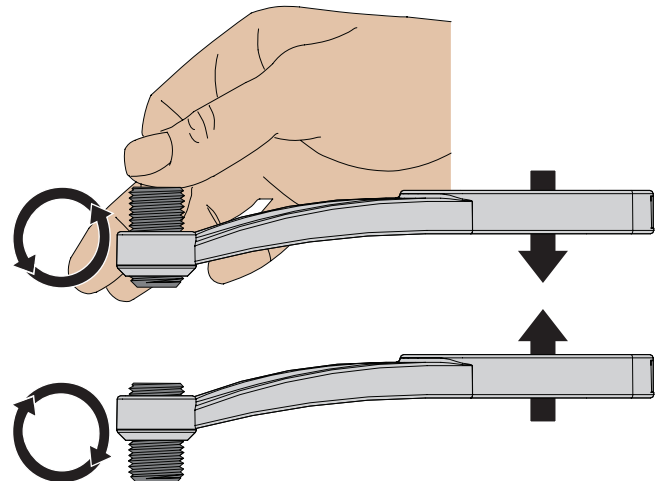

**Pro Tip****Mounting Hardware Too Long?**

The depth of some projector mount points may prevent you from tightening the M2.5 and M3 mounting hardware.

You can reduce the length of the M2.5 and M3 mounting hardware by stacking up to a maximum of five (5) M3 flat washers inside the leveling barrel.

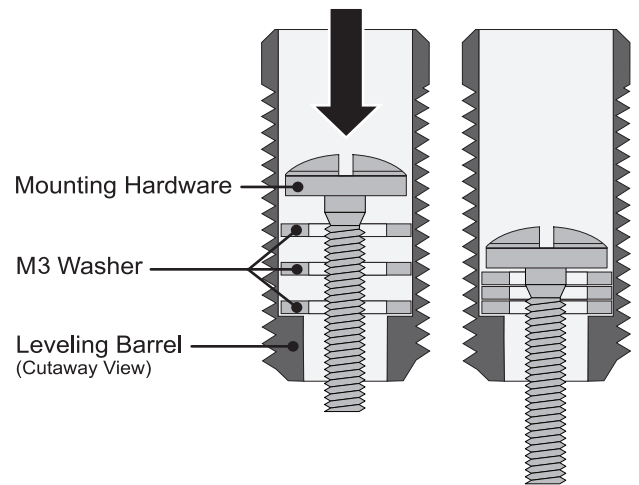

Avoid stacking too many M3 washers; the mounting hardware must thread into the projector mount point at least four (4) complete turns.

**Step 4**

- 1 Identify the projector's approximate front-to-back center of gravity. Place your hands on each side of the projector and gently lift it an inch from the surface on which it is resting. Carefully adjust your grip on the projector until it seems balanced from front-to-back. Mentally note the apparent center of gravity.
- 2 Identify the projector's approximate side-to-side center of gravity. Place your hands on the front and back of the projector and gently lift it an inch from the surface on which it is resting. Carefully adjust your grip on the projector until it seems balanced from side-to-side. Mentally note the apparent center of gravity.
- 3 Place the Projector Plate on top of the mounting legs with the center of the plate as close as possible to the projector's center of gravity.

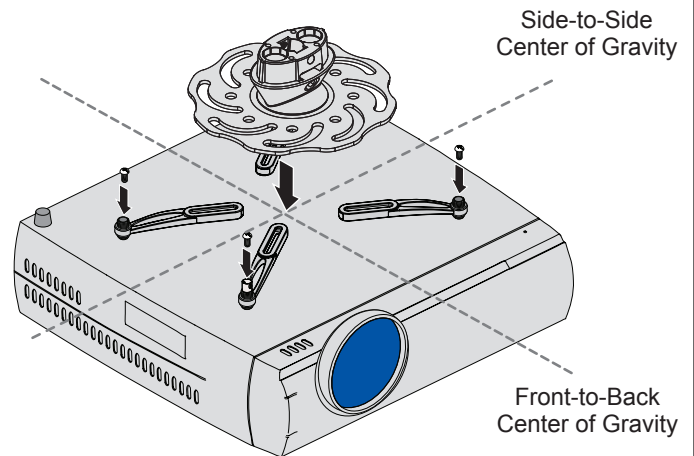
**Step 5**

- 1 Position the legs accordingly for best configuration. You may raise or lower each leg independently by turning the leveling barrels.
- 2 Secure the legs to the projector plate by screwing M6 x 12mm security screws into the M6 square nut (do not overtighten) on the mounting legs.
- 3 Verify the position of the integrated sliding M6 square nut in the mounting leg relative to a nearby slot on the Projector Plate.



If the M6 square nut is not aligned with any slot, you can use any thin implement, such as a toothpick, to nudge it into alignment.

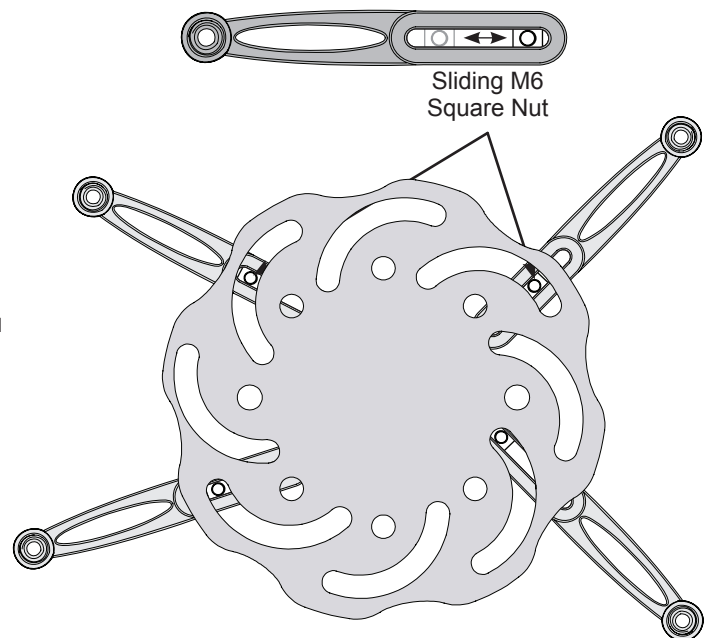



### Step 6

- 1 Tighten the mounting screws which secures the mounting legs to the projector.

 Do not overtighten the mounting screws.

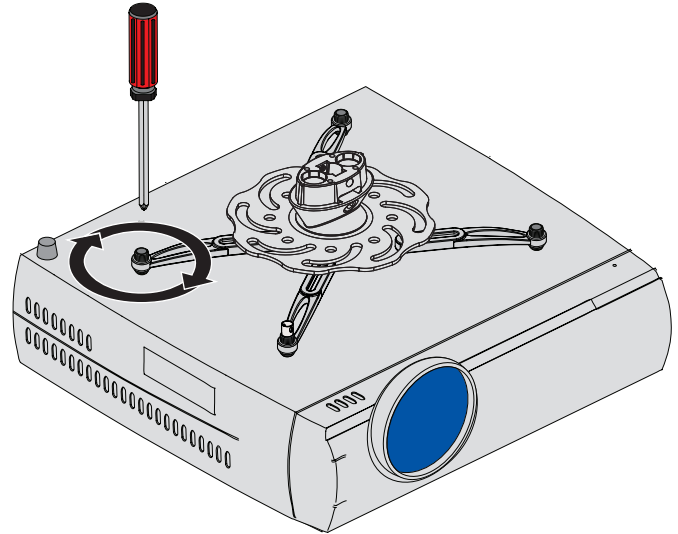

### Step 7

- 1 Attach the Projector Plate to each of the mounting legs by inserting and tightening one (1) M6 x 12mm screw through the Projector Plate into the M6 square nut on each of the mounting legs.

 Do not overtighten the M6 x 12mm screws.

- 2 Insert one (1) Barrel Cap into the end of each leveling barrel.

Proceed to the **“Single Mounting Point Installation”** section.

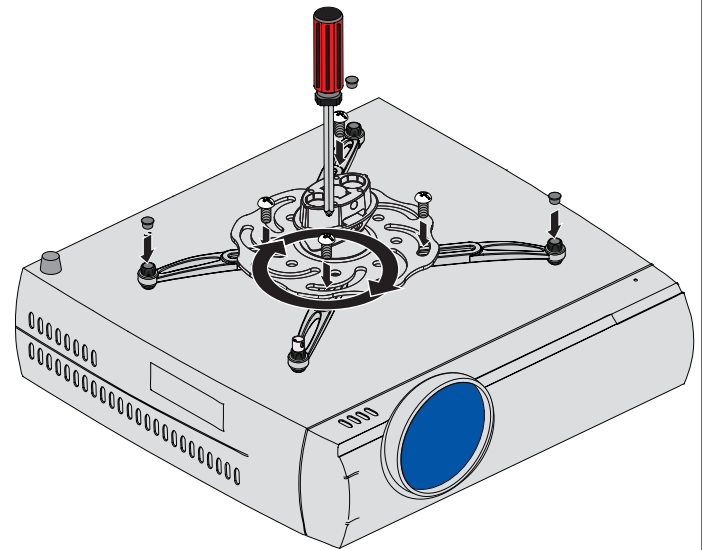

### Single Mounting Point Installation

A single  $\frac{1}{4}$ -20 x  $\frac{5}{16}$ " screw must be used to attach the Projector Plate to the projector if your projector has only one mounting point.

 Do not overtighten the  $\frac{1}{4}$ -20 x  $\frac{5}{16}$ " screw.

Proceed to the **“Installing the MAG Mount”** section.

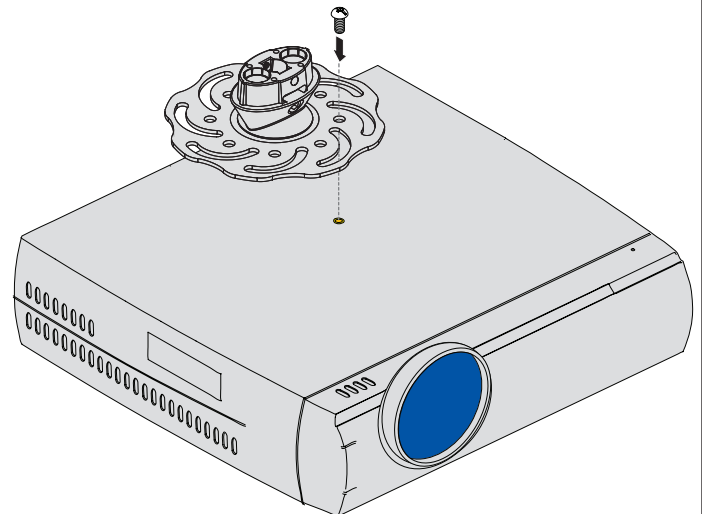



## Installing the MAG Mount

### Wood Stud Installation

#### Step 1

- 1 Use a stud finder to locate a ceiling stud closest to your desired installation location.
- 2 Identify the center of the ceiling stud.
- 3 Use a pencil to mark the location of the ceiling stud center.

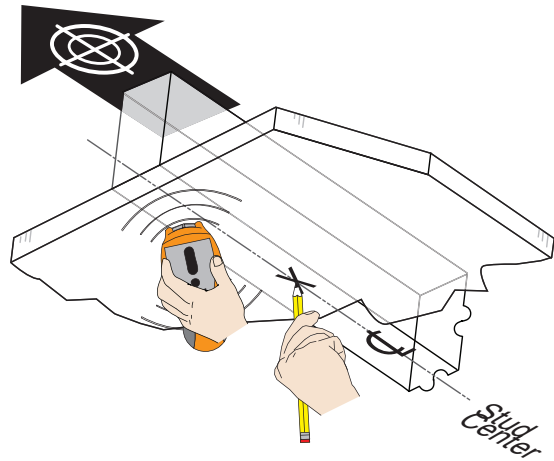

#### Step 2

- 1 Use a 1/8" drill bit to pre-drill the mounting holes before securing the wood screws (supplied).

Wood studs: Where denoted with the letter 'A', mark these locations for wood stud installation.

- 2 Use a masonry bit to pre-drill the mounting holes in the concrete surface.

Concrete surface: Where denoted with the letter 'B', mark these locations for concrete installation.

- 3 Use two (2) #14 x 2" wood screws (supplied) to attach the ceiling plate to the wooden ceiling stud.

For extra security, attach a third wood screw to the middle mounting point (A).

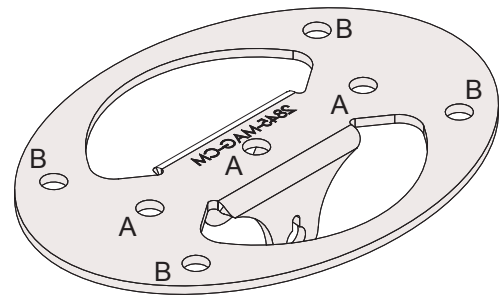

#### Step 3

- 1 Slowly raise the projector toward the upper assembly.
- 2 Once the projector is close to the upper assembly, MagnaGuide™ Technology will pull the lower assembly into the upper assembly and the locking tab will engage.

THE MAGNETS ARE USED FOR GUIDING THE UNIT ONLY! PLEASE MAKE SURE THE TWO (2) M4 X 12MM SCREWS ARE USED TO SECURE THE PROJECTOR.

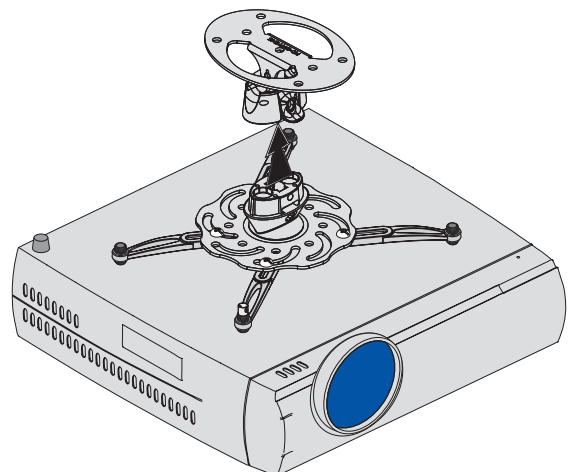



### Step 4

- 1 Attach the two (2) M4 x 12mm security screws and star washers that are located on each side of the locking tab.



Do not release your hold on the projector until the upper and lower assemblies are engaged and the locking tab is in place.

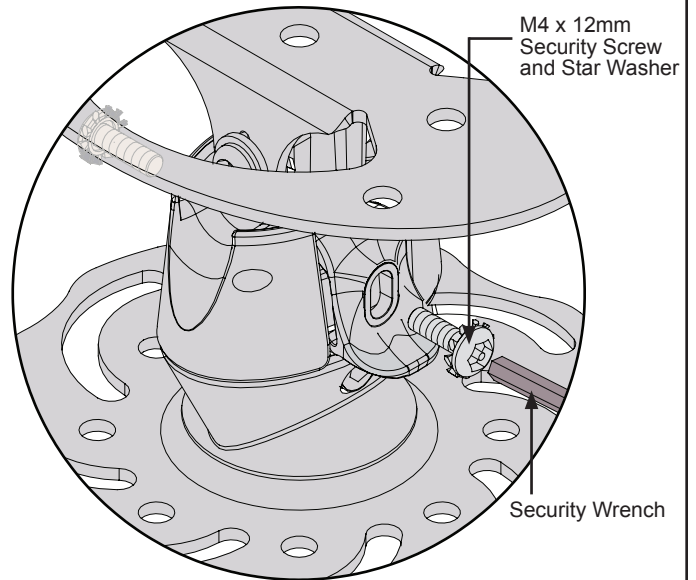

## Solid Surface Installation



The MAG Mount can be mounted to a ceiling with a minimum 6" thickness. Concrete wedge anchors must be used for concrete installation. It is recommended that 1/4" wedge anchors be used. A masonry bit must be used to drill the pilot hole. These can be purchased at your local hardware store.

- 1 Begin by placing the upper bridge into position against the ceiling, keeping it level.
- 2 Mark off four holes to be used for securing the mount and place the upper bridge aside.
- 3 Next, drill holes using the appropriate masonry bit for your anchor.
- 4 Insert a concrete anchor into each hole.
- 5 If necessary, a hammer can be used to lightly tap each anchor into place so that they are flush with the ceiling.
- 6 Once all of the anchors are in place, move the upper bridge back into position.
- 7 Attach the nut onto the threaded shaft that is protruding from the ceiling.
- 8 Do not tighten until all nuts are in place.

Proceed to the "**MAG Mount Adjustment**" section.

## MAG Mount Adjustment

### Step 1

After the projector has been installed, the projector must then be adjusted. To adjust the projector:

- 1 Loosen the M5 set screw using the M5 Allen wrench (both sides).
- 2 Adjust the projector to the correct position. Firmly grasp the projector in both hands, and tilt either forward or backward to adjust the level.

-OR-

- 3 Firmly grasp the projector in both hands and rotate side to side for orientation adjustment.
- 4 Tighten both M5 set screws using the M5 Allen wrench.

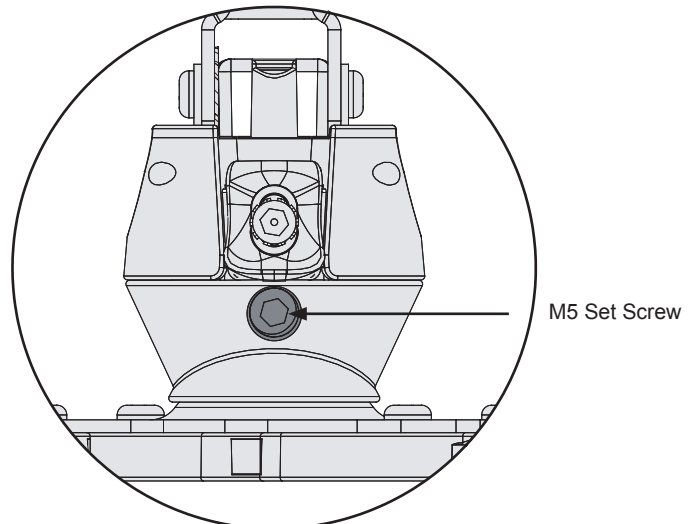



# Technical Specifications

All measurements are in inches [millimeters].

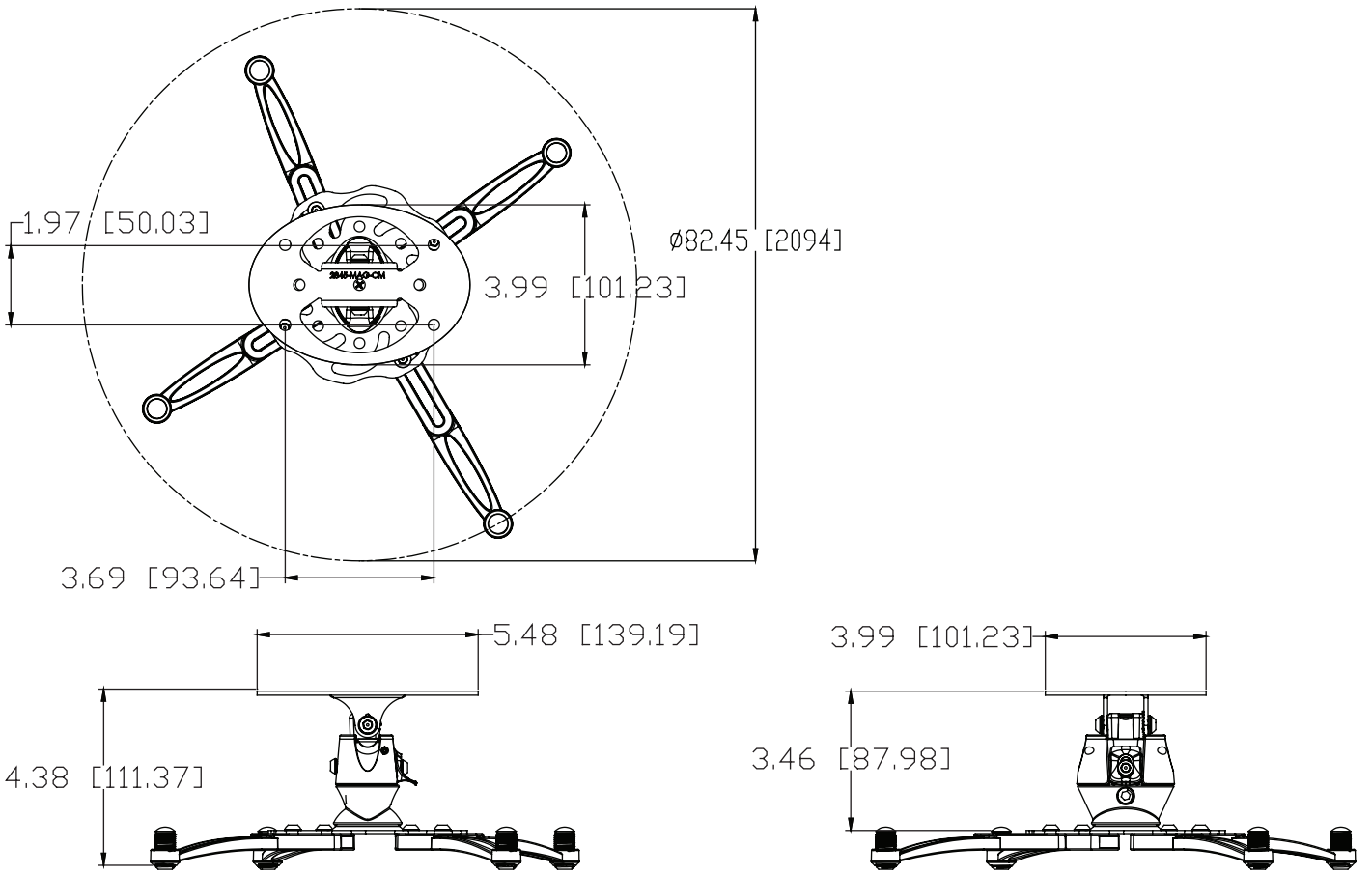



## Warranty

### PREMIER MOUNTS LIMITED LIFETIME WARRANTY

#### **What and Who is Covered by this Limited Warranty and for How Long**

Premier Mounts warrants this product to be free from defects in material and workmanship for the lifetime of the original owner of this product. The limited warranty is valid only for the original purchaser of the product.

#### **What Premier Mounts Will Do**

At the sole option of Premier Mounts, Premier Mounts will repair or replace any product or product part that is defective. If Premier Mounts chooses to replace a defective product or part, a replacement product or part will be shipped to you at no charge, but you must pay any labor costs.

#### **What is Not Covered; Limitations**

PREMIER MOUNTS DISCLAIMS ANY LIABILITY FOR DAMAGE TO MOUNTS, ADAPTERS, DISPLAYS, PROJECTORS, OTHER PROPERTY, OR PERSONAL INJURY RESULTING, IN WHOLE OR IN PART, FROM IMPROPER INSTALLATION, MODIFICATION, USE OR MISUSE OF ITS PRODUCTS.

PREMIER MOUNTS DISCLAIMS ALL OTHER WARRANTIES, EXPRESS OR IMPLIED, INCLUDING WARRANTIES OF MERCHANTABILITY AND FITNESS FOR A PARTICULAR PURPOSE. PREMIER MOUNTS IS NOT RESPONSIBLE FOR INCIDENTAL OR CONSEQUENTIAL DAMAGES, INCLUDING BUT NOT LIMITED TO, INABILITY TO USE ITS PRODUCTS OR LABOR COSTS FOR REMOVING AND REPLACING DEFECTIVE PRODUCTS OR PARTS. SOME STATES DO NOT ALLOW THE EXCLUSION OR LIMITATION OF INCIDENTAL OR CONSEQUENTIAL DAMAGES, SO THE ABOVE LIMITATION OR EXCLUSION MAY NOT APPLY TO YOU.

#### **What Customers Must Do for Limited Warranty Service**

If you discover a problem that you think may be covered by the warranty you **MUST REPORT** it in writing to the address below within thirty (30) days. Proof of purchase (an original sales receipt) from the original consumer purchaser must accompany all warranty claims. Warranty claims must also include a description of the problem, the purchaser's name, address, and telephone number. General inquiries can be addressed to Premier Mounts Customer Service at 1-800-368-9700. Warranty claims will not be accepted over the phone or by fax.

Premier Mounts  
Attn: Warranty Claim  
3130 East Miraloma Ave.  
Anaheim, CA 92806

#### **How State Law Applies**

THIS WARRANTY GIVES YOU SPECIFIC LEGAL RIGHTS, AND YOU MAY ALSO HAVE OTHER RIGHTS WHICH VARY FROM STATE TO STATE.

## Disclaimer

Premier Mounts intends to make this manual accurate and complete. However, Premier Mounts makes no claim that the information contained herein covers all details, conditions or variations, nor does it provide for every possible contingency in connection with the installation or use of this product. The information contained in this document is subject to change without notice or obligation of any kind. Premier Mounts makes no representation of warranty, expressed or implied, regarding the information contained herein. Premier Mounts assumes no responsibility for accuracy, completeness or sufficiency of the information contained in this document.